

## Power Panel Integrated control, operation and visualization

The compact and intelligent PP15, PP21, and PP41 Power Panel devices are the first choice for automating small to mid-sized machines and systems with maximum component density.



## Table of contents

<b>System characteristics .....</b>	<b>790</b>
<b>Typical topologies .....</b>	<b>795</b>
<b>Product overview .....</b>	<b>798</b>
<b>Product data sheets .....</b>	<b>804</b>
<b>Dimensions .....</b>	<b>860</b>
<b>Legend strips .....</b>	<b>868</b>

# System characteristics

## Redefining performance

The compact and intelligent Power Panels PP15, PP21, PP35 and PP41 are the first choice for automation on small to mid-size machines and systems with maximum component density. These products integrate the visualization, a complete PLC, and digital inputs and outputs. In addition, these devices can be modularly expanded and are available in variations with text display and graphics with up to QVGA resolution.

Even higher demands are met by the Power Panel 45, Power Panel 300 and Power Panel 400 product lines. Their area of use may range from simple operator terminals and visualizations with a standard operating system to complete automation systems with integrated control and drive technology. Whether stand-alone or networked, the possibilities are endless.

Power Panel 300 embedded devices can be used as a terminal in one system or distributed over several operator stations.

Power Panel 400 devices additionally offer all of the functions of a controller, including modular fieldbus interfaces and input systems that range from analog resistive touch screens to various keyboard devices.

## Power Panel overview

	PP15	PP35	PP21	PP41	PP45	PP300	PP400
Display	LCD 4 x 20 characters	LCD 160 x 80 pixels	LCD 4 x 20 characters	LCD QVGA	LCD QVGA	LCD/TFT QVGA VGA SVGA XGA	LCD/TFT QVGA VGA XGA
Covered keys	Yes	Yes	Yes	Yes	Yes	No	Yes
Touch screen	-	-	-	-	Yes	Yes	Yes
Memory	300 KB SRAM 1024 KB/1984 KB User PROM	300 KB SRAM 1024 KB/1984 KB User PROM	700 KB SRAM 1.4 MB User PROM	700 KB SRAM 1.4 MB User PROM	64 MB DRAM 32 KB SRAM	128 MB SDRAM <sup>1)</sup> 256/512 MB SDRAM <sup>2)</sup>	128 MB SDRAM 512 KB SRAM
Inputs/outputs on-board	Yes	Yes	Yes	Yes	No	No	No
Interfaces On-board	CAN bus RS232	CAN bus RS232	CAN bus RS232	CAN bus RS232	X2X	RS232	RS232
Ethernet TCP/IP on-board/modular	- / -	- / -	- / -	- / Yes	Yes / -	Yes / -	Yes / -
Expansion modules	-	-	Max. 6 B&R 2003 screw-in modules	Max. 6 B&R 2003 screw-in modules 1 B&R 2005 communication module	Max. 1 PP45 compact IF slot	-	Max. 2 aPCI modules
Instruction cycle time	0.8 µs	0.8 µs	0.5 µs	0.5 µs	TBD	- <sup>3)</sup>	0.038 µs <sup>1)</sup>

1) Embedded variations

2) BIOS variations

3) No controller functionality

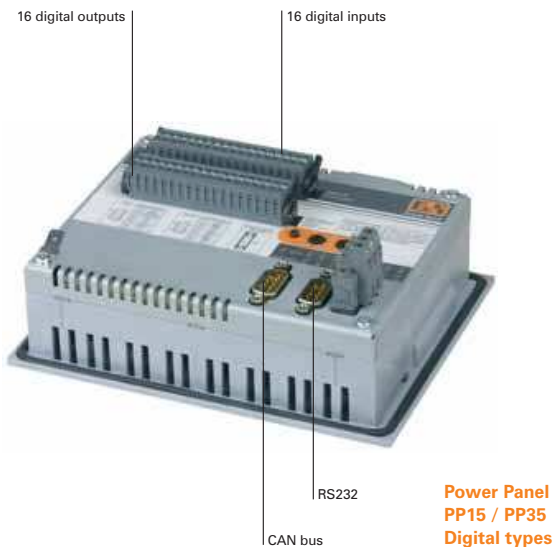

**Power Panel  
PP15 / PP35  
Digital types**

## PP15 / PP21 / PP35 / PP41

### Compact control and visualization devices

The devices in the Power Panel model range from PP15 to PP41 integrate controller, onboard I/O and visualization. This product family is especially noteworthy for its compact design and extensive range of functions. An integrated CAN bus interface is available for connecting additional input/output channels or drives. Programming applications and the visualization project can be done using Automation Studio, the programming and diagnostics tool from B&R.

### The same aspect ratio for graphics or text

PP15 and PP35 devices offer a choice between a 4 x 20 character or 160 x 80 pixel graphic display with the same outer dimensions.

### Modularly expandable

In addition to the integrated inputs/outputs, the PP21 and PP41 are also equipped with six expansion slots. This enables expansion with up to 60 digital or 24 analog inputs/outputs. Three slots can be used for modules with TPU functionality. As a result, functions such as event counting, trigger function, stepper motor control and frequency measurement are possible. As an additional option, the PP41 offers an expansion slot for System 2005 communication modules. This makes it possible to connect Ethernet TCP/IP in addition to fieldbus systems. Character sets and language modules for the visualization unit are stored on a CompactFlash card that can be exchanged from the outside.

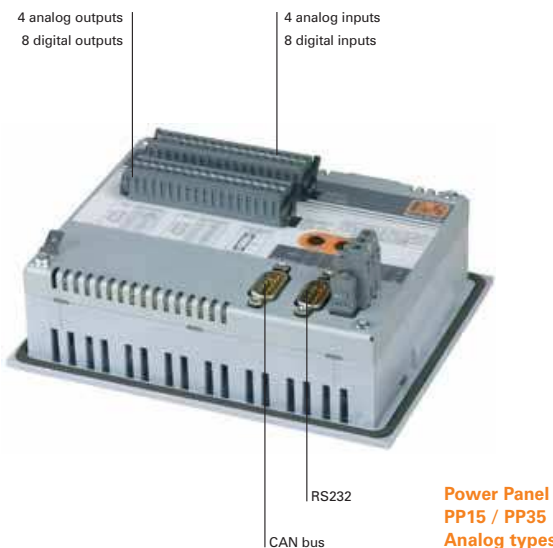

**Power Panel  
PP15 / PP35  
Analog types**

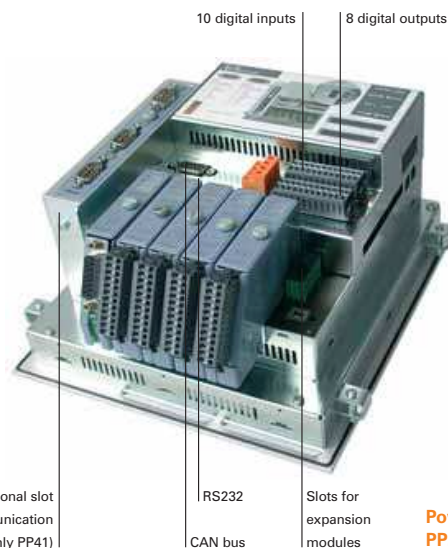

**Power Panel  
PP21 / PP41**

## System characteristics



Model number	Type	Display	Resolution	Digital inputs/outputs	Analog inputs/outputs	CAN bus	Ethernet	
4PP015.0420-01	PP15	LCD	4x20 characters	16 / 16	- / -	✓	-	804
4PP015.0420-36	PP15	LCD	4x20 characters	8 / 8	4 / 4	✓	-	804
4PP015.C420-01	PP15	LCD	4x20 characters	16 / 16	- / -	✓	-	804
4PP015.C420-36	PP15	LCD	4x20 characters	8 / 8	4 / 4	✓	-	804
4PP015.E420-01	PP15	LCD	4x20 characters	16 / 16	- / -	✓	-	804
4PP015.E420-101	PP15	LCD	4x20 characters	16 / 16	- / -	✓	-	807
4PP015.E420-36	PP15	LCD	4x20 characters	8 / 8	4 / 4	✓	-	804
4P0420.00-490	PP21	LCD	4x20 characters	10 / 8	- / -	✓	-	804
4PP035.0300-01	PP35	LCD	160x80 pixels	16 / 16	- / -	✓	-	809
4PP035.0300-36	PP35	LCD	160x80 pixels	8 / 8	4 / 4	✓	-	809
4PP035.E300-01	PP35	LCD	160x80 pixels	16 / 16	- / -	✓	-	809
4PP035.E300-36	PP35	LCD	160x80 pixels	8 / 8	4 / 4	✓	-	809
4PP035.E300-136	PP35	LCD	160x80 pixels	8 / 8	4 / 4	✓	-	812
4P3040.01-490	PP41	LCD	QVGA	10 / 8	- / -	✓	✓	816

### Power Panel 45



Model number	Diagonal [in]	Display	Resolution	Touch screen	DRAM [MB]	SRAM [KB]	aPCI slots	Ethernet	
4PP045.0571-042	5.7	LCD m	QVGA	✓	64	32	0	✓	821
4PP045.0571-062	5.7	LCD color	QVGA	✓	64	32	0	✓	822
4PP045.0571-L42	5.7	LCD m	QVGA	-	64	32	0	✓	823

### Power Panel 300 BIOS

#### Universal application

Power Panel 300 devices with BIOS are set up for use with Windows® CE .net or Windows® XP embedded. This allows these devices to be used universally with standard SCADA packages as web terminals or thin clients.



Model number	Type	Diagonal [in]	Display	Resolution	Touch screen	DRAM [MB]	SRAM [KB]	aPCI slots	Ethernet	
5PP320.0571-39	BIOS	5.7	TFT color	QVGA	✓	256	-	0	✓	828
5PP320.0573-39	BIOS	5.7	TFT color	VGA	✓	256	-	0	✓	830
5PP320.0573-3B	BIOS	5.7	TFT color	VGA	✓	512	-	0	✓	830
5PP320.1043-39	BIOS	10.4	TFT color	VGA	✓	256	-	0	✓	831
5PP320.1214-39	BIOS	12.1	TFT color	SVGA	✓	256	-	0	✓	832
5PP320.1505-39	BIOS	15	TFT color	XGA	✓	256	-	0	✓	833

## Power Panel 300 embedded

### More than visualization

Devices in the Power Panel 300 embedded product line are visualization terminals that can be connected to additional Power Panel terminals, industrial PCs, controllers, or any other high-level computer system. However, the Power Panel 300 is more than just a simple display unit. In addition to handling its visualization tasks, the Power Panel 300 can also execute any software component that can run on a controller. Power Panel 100 devices can be programmed with Automation Studio, our extensive configuration and programming tool.

### Distributed or central data storage

The data points are stored either on a central controller (terminal mode) or directly on the Power Panel CompactFlash.

### Open communication

The RS232 and Ethernet interfaces on the Power Panel 300/400 can be programmed as needed. This makes it possible to couple various peripherals or to connect with higher level systems.

## Power Panel 400 embedded

### Integrating control and motion technology

Power Panel 400 devices integrate both control and drive technology. The devices are equipped with up to two slots for interface modules. CAN bus, X2X Link or POWERLINK connections are supported.

### Programming with Automation Studio

Automation Studio handles uniform configuration and programming of the controller and visualization. Combining a Power Panel 300 and 400 in terminal mode achieves an even higher level of freedom. For example, a Power Panel 400 located on one side of the machine can handle all the control and visualization tasks, while a Power Panel 300 on the other side of the machine can manage a second visualization application.

## Power Panel 300/400



Model number	Type	Diagonal [in]	Display	Resolution	Touch screen	DRAM [MB]	SRAM [KB]	aPCI slots	Ethernet	
4PP320.0571-01	Embedded	5.7	LCD m	QVGA	✓	128	-	0	✓	834
4PP320.0571-35	Embedded	5.7	TFT color	QVGA	✓	128	-	0	✓	835
4PP420.0571-45	Embedded	5.7	LCD m	QVGA	✓	128	512	1	✓	842
4PP420.0571-75	Embedded	5.7	TFT color	QVGA	✓	128	512	1	✓	844
4PP420.0571-85	Embedded	5.7	LCD m	QVGA	✓	128	512	2	✓	842
4PP420.0571-B5	Embedded	5.7	TFT color	QVGA	✓	128	512	2	✓	844
4PP420.0573-75	Embedded	5.7	TFT color	VGA	✓	128	512	1	✓	845



4PP351.0571-01	Embedded	5.7	LCD m	QVGA	✓	128	-	0	✓	838
4PP351.0571-31	Embedded	5.7	TFT color	QVGA	✓	128	-	0	✓	839
4PP451.0571-45	Embedded	5.7	LCD m	QVGA	✓	128	512	1	✓	848
4PP451.0571-75	Embedded	5.7	TFT color	QVGA	-	128	512	1	✓	849
4PP451.0571-85	Embedded	5.7	LCD m	QVGA	✓	128	512	2	✓	848
4PP451.0571-B5	Embedded	5.7	TFT color	QVGA	✓	128	512	2	✓	849



4PP352.0571-35	Embedded	5.7	TFT color	QVGA	-	128	-	0	✓	840
4PP452.0571-45	Embedded	5.7	LCD m	QVGA	-	128	512	1	✓	850
4PP452.0571-75	Embedded	5.7	TFT color	QVGA	-	128	512	1	✓	851
4PP452.0571-B5	Embedded	5.7	TFT color	TFT color	-	128	512	2	✓	851



4PP320.1043-31	Embedded	10.4	TFT color	VGA	✓	128	-	0	✓	836
4PP420.1043-75	Embedded	10.4	TFT color	VGA	✓	128	512	1	✓	846
4PP420.1043-B5	Embedded	10.4	TFT color	VGA	✓	128	512	2	✓	846

## System characteristics

### Power Panel 300 / 400 (continued)



Model number	Type	Diagonal [in]	Display	Resolution	Touch screen	DRAM [MB]	SRAM [KB]	aPCI slots	Ethernet	
4PP480.1043-75	Embedded	10.4	TFT color	VGA	✓	128	512	1	✓	852



4PP381.1043-31	Embedded	10.4	TFT color	VGA	✓	128	-	0	✓	841
4PP451.1043-75	Embedded	10.4	TFT color	VGA	-	128	512	1	✓	854
4PP451.1043-B5	Embedded	10.4	TFT color	VGA	-	128	512	1	✓	854
4PP481.1043-75	Embedded	10.4	TFT color	VGA	✓	128	512	1	✓	855
4PP481.1043-B5	Embedded	10.4	TFT color	VGA	✓	128	512	2	✓	855



4PP452.1043-75	Embedded	10.4	TFT color	VGA	✓	128	512	1	✓	857
4PP482.1043-75	Embedded	10.4	TFT color	VGA	✓	128	512	1	✓	858



4PP320.1505-31	Embedded	15	TFT color	XGA	✓	128	-	0	✓	837
4PP420.1505-75	Embedded	15	TFT color	XGA	✓	128	512	1	✓	847
4PP420.1505-B5	Embedded	15	TFT color	XGA	✓	128	512	2	✓	847



4PP480.1505-75	Embedded	15	TFT color	XGA	✓	128	512	1	✓	853
4PP480.1505-B5	Embedded	15	TFT color	XGA	✓	128	512	1	✓	853



4PP481.1505-75	Embedded	15	TFT color	XGA	✓	128	512	1	✓	856
----------------	----------	----	-----------	-----	---	-----	-----	---	---	-----



# Typical topologies

## Distributed systems

In a distributed system, two or more Power Panel devices are connected to each other over a CAN bus. Control programs run on each Power Panel. The sensors and actuators are connected to the integrated inputs and outputs as well as the remote CAN bus stations.

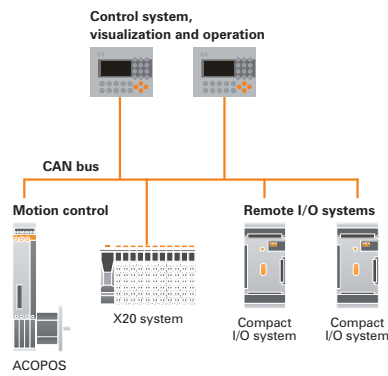

### Components and technologies

Control system	Power Panel: Integrated control, operation, and visualization	787
Visualization and operation	Power Panel: Integrated control, operation, and visualization	787
Motion control	ACOPOS: Intelligent servo drives	1251
	ACOPOSmulti: Modular drive system	1321
Remote I/O systems	Compact I/O System: Space-saving peripheral connections	581
	X20 System: Slice-based I/O and control system	37

# Typical topologies

## Power Panel as an intelligent visualization device

The visualization project runs on the Power Panel. Serial RS232 or Ethernet TCP/IP provides the communication to the control. Flexible programming with frame drivers or Ethernet socket services allows a connection to be made to any control system. I/O peripherals and drives are connected to the controller.

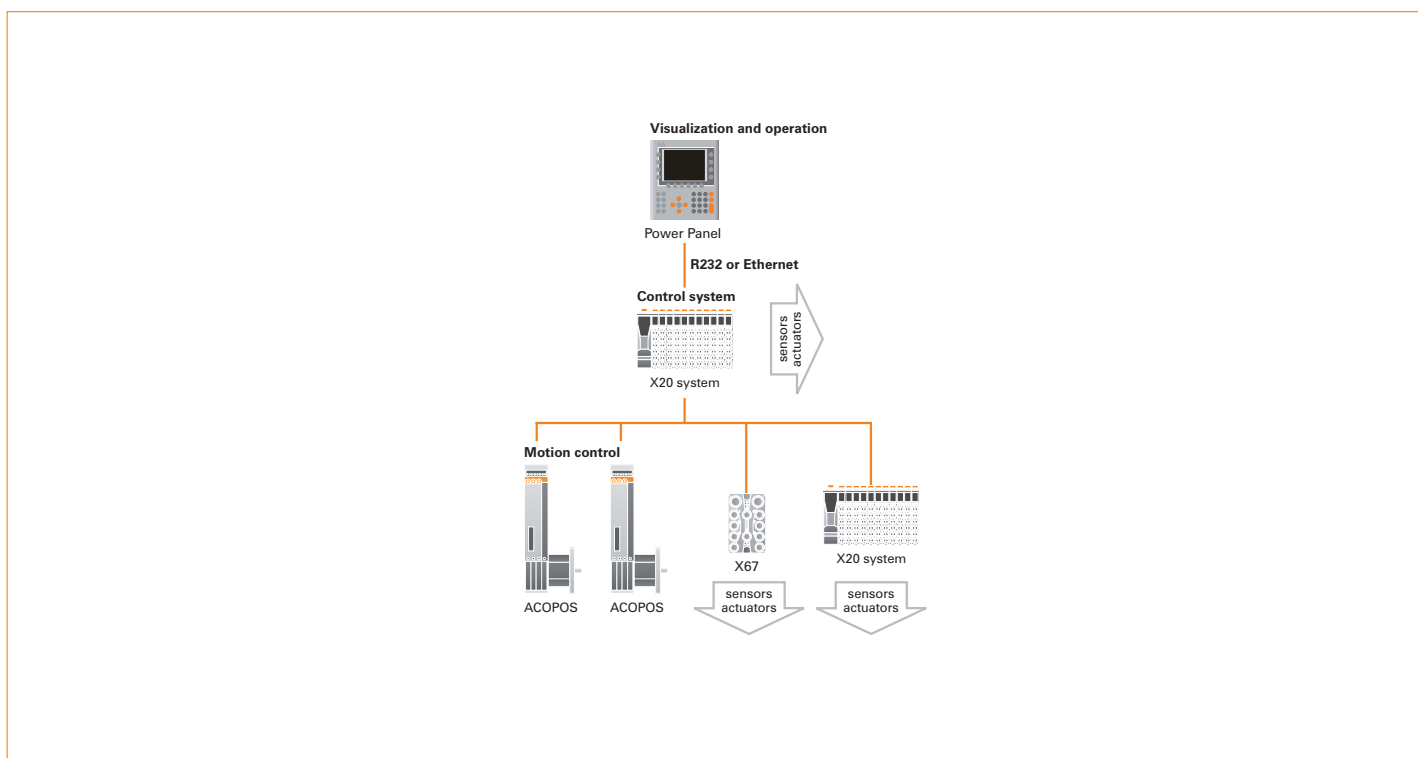

### Components and technologies

Control system	X20 System: Slice-based I/O and control system	37
Visualization and operation	Power Panel: Integrated control, operation, and visualization	787
Motion control	ACOPOS: Intelligent servo drives	1251
	ACOPOSmulti: Modular drive system	1321
Remote I/O systems	X20 System: Slice-based I/O and control system	37
	X67 System: Remote I/O with IP67 protection	419

## Power Panel 400 with Power Panel 300 terminals

The control program and visualization run on the Power Panel 400. I/O peripherals and drives are connected via a CAN bus, POWERLINK, or another network type. Other Power Panel 300 units are connected as terminals over Ethernet TCP/IP.

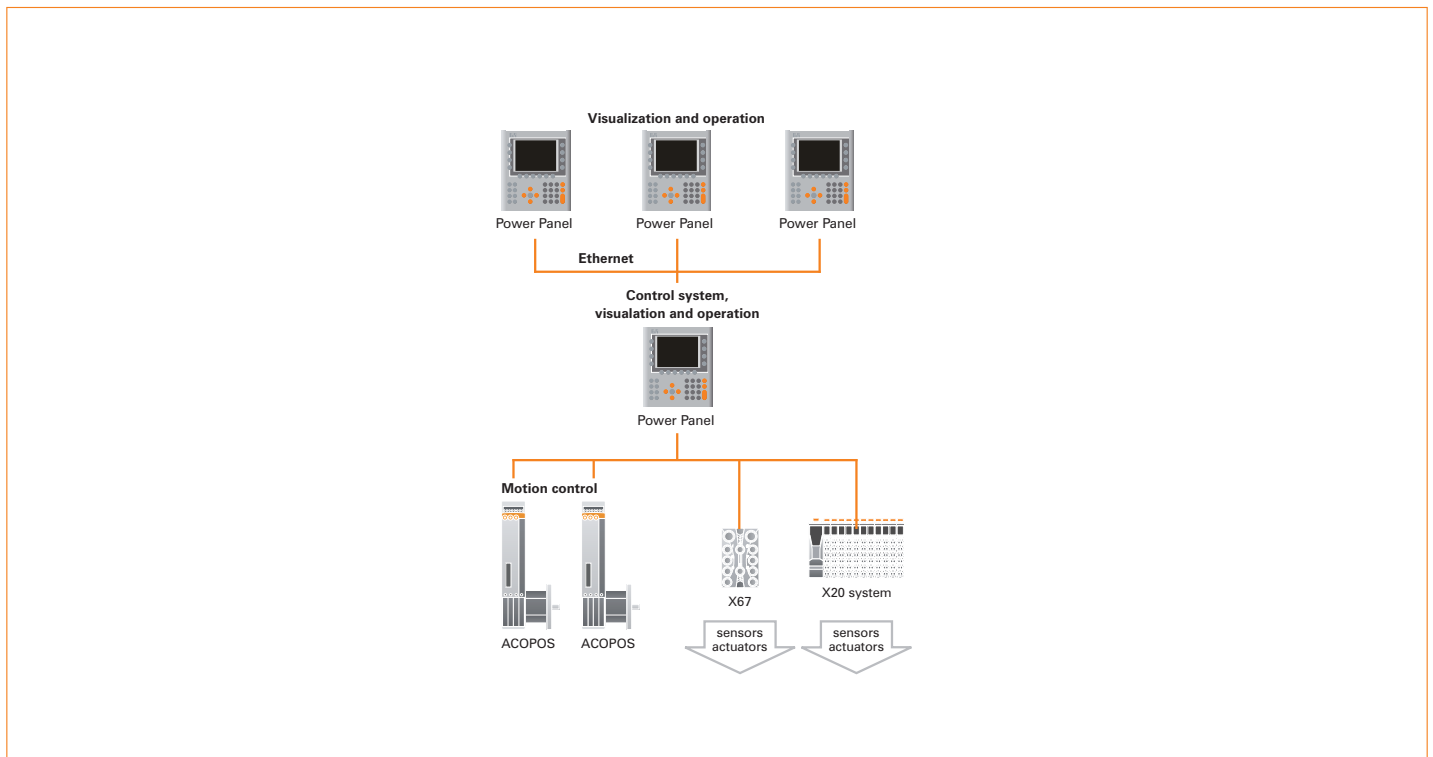

### Components and technologies

Control system	Power Panel: Integrated control, operation, and visualization	787
Visualization and operation	Power Panel: Integrated control, operation, and visualization	787
Motion control	ACOPOS: Intelligent servo drives	1251
	ACOPOSmulti: Modular drive system	1321
Remote I/O systems	X20 System: Slice-based I/O and control system	37
	X67 System: Remote I/O with IP67 protection	419

# Product overview

## Power Panel PP15 / PP35



Model number	Short description	
4PP015.0420-01	Power Panel PP15, LCD, 4x20 characters, 16 keys (10 with legend strips), 300 KB SRAM, 1024 KB FlashPROM, RS232, CAN bus, 16 digital inputs 24 VDC, 16 digital outputs 24 VDC, 0.5 A, IP65 protection (front side). 24 VDC.	804
4PP015.0420-36	Power Panel PP15, LCD, 4x20 characters, 16 keys (10 with legend strips), 300 KB SRAM, 1024 KB FlashPROM, RS232, CAN bus, 8 digital inputs 24 VDC, 8 digital outputs 24 VDC, 0.5 A, 4 analog inputs, 4 analog outputs. IP65 protection (front side). 24 VDC.	804
4PP015.C420-01	Power Panel PP15, LCD, 4x20 characters, 26 keys (10 with legend strips), 300 KB SRAM, 1024 KB FlashPROM, RS232, CAN bus, 16 digital inputs 24 VDC, 16 digital outputs 24 VDC, 0.5 A, IP65 protection (front side). 24 VDC.	804
4PP015.C420-36	Power Panel PP15, LCD, 4x20 characters, 26 keys (10 with legend strips), 300 KB SRAM, 1024 KB FlashPROM, RS232, CAN bus, 8 digital inputs 24 VDC, 8 digital outputs 24 VDC, 0.5 A, 4 analog inputs, 4 analog outputs. IP65 protection (front side). 24 VDC.	804
4PP015.E420-01	Power Panel PP15, LCD, 4x20 characters, 26 keys (10 with legend strips), 300 KB SRAM, 1024 KB FlashPROM, RS232, CAN bus, 16 digital inputs 24 VDC, 16 digital outputs 24 VDC, 0.5 A, IP65 protection (front side). 24 VDC.	804
4PP015.E420-101	Power Panel PP15, LCD, 4x20 characters, 26 keys (10 with legend strips), 300 KB SRAM, 1984 KB FlashPROM, RS232, CAN bus, 16 digital inputs 24 VDC, 16 digital outputs 24 VDC, 0.5 A, IP65 protection (front side). 24 VDC.	807
4PP015.E420-36	Power Panel PP15, LCD, 4x20 characters, 26 keys (10 with legend strips), 300 KB SRAM, 1024 KB FlashPROM, RS232, CAN bus, 8 digital inputs 24 VDC, 8 digital outputs 24 VDC, 0.5 A, 4 analog inputs, 4 analog outputs. IP65 protection (front side). 24 VDC.	804
4PP035.0300-01	Power Panel PP35, LCD, 160x80 pixels, 16 keys (10 with legend strips), 300 KB SRAM, 1024 KB FlashPROM, RS232, CAN bus, 16 digital inputs 24 VDC, 16 digital outputs 24 VDC, 0.5 A, IP65 protection (front side). 24 VDC.	809
4PP035.0300-36	Power Panel PP35, LCD, 160x80 pixels, 16 keys (10 with legend strips), 300 KB SRAM, 1024 KB FlashPROM, RS232, CAN bus, 8 digital inputs 24 VDC, 8 digital outputs 24 VDC, 0.5 A, 4 analog inputs, 4 analog outputs. IP65 protection (front side). 24 VDC.	809
4PP035.E300-01	Power Panel PP35, LCD, 160x80 pixels, 26 keys (10 with legend strips), 300 KB SRAM, 1024 KB FlashPROM, RS232, CAN bus, 16 digital inputs 24 VDC, 16 digital outputs 24 VDC, 0.5 A, IP65 protection (front side). 24 VDC.	809
4PP035.E300-36	Power Panel PP35, LCD, 160x80 pixels, 26 keys (10 with legend strips), 300 KB SRAM, 1024 KB FlashPROM, RS232, CAN bus, 8 digital inputs 24 VDC, 8 digital outputs 24 VDC, 0.5 A, 4 analog inputs, 4 analog outputs. IP65 protection (front side). 24 VDC.	809
4PP035.E300-136	Power Panel PP35, LCD, 160x80 pixels, 26 keys (10 with legend strips), 300 KB SRAM, 1984 KB FlashPROM, RS232, CAN bus, 8 digital inputs 24 VDC, 8 digital outputs 24 VDC, 0.5 A, 4 analog inputs, 4 analog outputs. IP65 protection (front side). 24 VDC.	812

## Power Panel PP21/PP41



Model number	Short description	
4P0420.00-490	Power Panel PP21, LCD, 4x20 characters, background lighting, 34 function keys, system compatible 2003 CPU, 700 KB SRAM, 1.4 MB FlashPROM, 1 PC card slot, 1 RS232 interface, 1 CAN bus interface (electrically isolated, network-capable), 6 slots for screw-in modules, 10 digital inputs 24 VDC, 8 digital outputs 24 VDC, 0.4 A, IP65 protection (front side), 155 x 190 mm (W x H), 24 VDC.	816
4P3040.01-490	Power Panel PP41, 5.7" QVGA b/w LC display, 8 soft keys and 32 function keys, compatible with 2003 CPU, 700 KB SRAM, 1.4 MB FlashPROM, 1 PC card slot, 1 RS232 interface, 1 CAN bus interface (electrically isolated, network-capable), 6 slots for screw-in modules, 10 digital inputs 24 VDC, 8 digital outputs 24 VDC, 0.4 A, IP65 protection (front side), 205 x 220 mm (W x H), 24 VDC.	818

## Power Panel PP45



Model number	Short description	
4PP045.0571-042	Power Panel PP45, 5.7" QVGA m LCD with touch screen (resistive), 64 MB DRAM, CompactFlash slot (type I), ETH 10/100, 2x USB, X2X Link master interface, battery, IP65 protection (front side), 24 VDC.	821
4PP045.0571-062	Power Panel PP45, 5.7" QVGA color LC display with touch screen (resistive), 64 MB DRAM, CompactFlash slot (type I), ETH 10/100, 2x USB, X2X Link master interface, battery, IP65 protection (front side); 24 VDC.	822
4PP045.0571-L42	Power Panel PP45, 5.7" QVGA m LC display with 24 keys (6 with legend strips), 64 MB DRAM, CompactFlash slot (type I), ETH 10/100, X2X Link master interface, battery, IP65 protection (front side); 24 VDC.	823
4PP045.IF10-1	PP45 interface module, 1x RS232	824
4PP045.IF23-1	PP45 interface module, 1x RS232/422/485, RS422/485 electrically isolated and network-capable, 1x CAN, electrically isolated and network-capable	825
4PP045.IF24-1	PP45 interface module, 1x RS232/422/485, RS422/485 electrically isolated and network-capable, 1x Profibus DP slave, electrically isolated and network-capable	826
4PP045.IF33-1	PP45 interface module, 2x CAN, electrically isolated and network capable	827

# Product overview

## Power Panel 300 BIOS



Model number	Short description	
5PP320.0571-39	Power Panel PP320 BIOS 5.7" QVGA color TFT display with touch screen (resistive); 256 MB SDRAM; Compact Flash slot (type I); ETH 10/100; RS 232, 2x USB; battery; metal housing, IP65 protection (front side); 24 VDC.	828
5PP320.0573-39	Power Panel PP320 BIOS 5.7" VGA color TFT display with touch screen (resistive); 256 MB SDRAM; Compact Flash slot (type I); ETH 10/100; RS 232, 2x USB; battery; metal housing, IP65 protection (front side); 24 VDC.	830
5PP320.0573-3B	Power Panel PP320 BIOS; 5.7" VGA color TFT display with touch screen (resistive); 512 MB SDRAM; CompactFlash slot (type I), ETH 10/100, RS 232, 2x USB; battery; metal housing, IP 65 protection (front side); 24 VDC.	830
5PP320.1043-39	Power Panel PP320 BIOS 10.4" VGA color TFT display with touch screen (resistive); 256 MB SDRAM; CompactFlash slot (type I); ETH 10/100; RS 232, 2x USB; battery; metal housing, IP65 protection (front side); 24 VDC	831
5PP320.1214-39	Power Panel PP320 BIOS 12.1" SVGA color TFT display with touch screen (resistive); 256 MB SDRAM; Compact Flash slot (type I); ETH 10/100; RS 232, 2x USB; battery; metal housing, IP65 protection (front side); 24 VDC.	832
5PP320.1505-39	Power Panel PP320 BIOS 15" XGA color TFT display with touch screen (resistive); 256 MB SDRAM; Compact Flash slot (type I); ETH 10/100; RS 232, 2x USB; battery; metal housing, IP65 protection (front side); 24 VDC	833

## Power Panel 300 embedded



Model number	Short description	
4PP320.0571-01	Power Panel PP320, 5.7" QVGA monochrome LC display with touch screen (resistive), 128 MB SDRAM; CompactFlash slot (type I), ETH 10/100, RS232, 2x USB, metal housing, IP65 protection (front side), 24 VDC.	834
4PP320.0571-35	Power Panel PP320, 5.7" QVGA TFT color display with touch screen (resistive), 128 MB SDRAM; CompactFlash slot (type I), ETH 10/100, RS232, 2x USB, metal housing, IP65 protection (front side), 24 VDC.	835
4PP320.1043-31	Power Panel PP320, 10.4" VGA color TFT display with touch screen (resistive), 128 MB SDRAM; CompactFlash slot (type I), ETH 10/100, RS232, 2x USB, metal housing, IP65 protection (front side), 24 VDC.	836
4PP320.1505-31	Power Panel PP320, 15" XGA color TFT display with touch screen (resistive), 128 MB SDRAM; CompactFlash slot (type I), ETH 10/100, RS232, 2x USB, metal housing, IP65 protection (front side), 24 VDC.	837
4PP351.0571-01	Power Panel PP351, 5.7" QVGA monochrome LC display; 6 soft keys; 16 function keys and 20 system keys; 128 MB SDRAM; CompactFlash slot (type I); ETH 10/100; RS 232; 2x USB; metal housing, IP65 protection (front side); 24 VDC.	838
4PP351.0571-35	Power Panel PP351, 5.7" QVGA color TFT display; 6 soft keys; 16 function keys and 20 system keys; 128 MB SDRAM; CompactFlash slot (type I); ETH 10/100; RS 232; 2x USB; metal housing, IP65 protection (front side); 24 VDC.	839
4PP352.0571-35	Power Panel PP352, 5.7" QVGA color TFT display; 20 function keys and 20 system keys; 128 MB SDRAM; CompactFlash slot (type I); ETH 10/100; RS 232; 2x USB; metal housing, IP65 protection (front side); 24 VDC.	840
4PP381.1043-31	Power Panel PP381; 10.4" VGA color TFT display with touch screen (resistive); 10 soft keys; 28 function keys and 20 system keys; 128 MB SDRAM; CompactFlash slot (type I); ETH 10/100; RS 232; 2x USB; metal housing, IP65 protection (front side); 24 VDC.	841



# Product overview

## Power Panel 400 embedded



Model number	Short description	
4PP420.0571-45	Power Panel PP420, 5.7" QVGA m LC display with touch screen (resistive); 1 aPCI slot; 128 MB SDRAM; 512 KB SRAM; CompactFlash slot (type I), ETH 10/100, RS232, 2x USB; battery; metal housing, IP65 protection (front side); 24 VDC.	842
4PP420.0571-75	Power Panel PP420, 5.7" QVGA color TFT display with touch screen (resistive); 1 aPCI slot; 128 MB SDRAM; 512 KB SRAM; CompactFlash slot (type II), ETH 10/100, RS232, 2x USB; battery; metal housing, IP65 protection (front side); 24 VDC.	844
4PP420.0571-85	Power Panel PP420, 5.7" QVGA monochrome LC display with touch screen (resistive); 2 aPCI slots; 128 MB SDRAM; 512 KB SRAM; CompactFlash slot (type II), ETH 10/100, RS232, 2x USB; battery; metal housing, IP65 protection (front side); 24 VDC.	842
4PP420.0571-B5	Power Panel PP420, 5.7" QVGA color TFT display with touch screen (resistive); 2 aPCI slot; 128 MB SDRAM; 512 KB SRAM; CompactFlash slot (type II), ETH 10/100, RS232, 2x USB; battery; metal housing, IP65 protection (front side); 24 VDC.	844
4PP420.0573-75	Power Panel PP420, 5.7" VGA color TFT display with touch screen (resistive); 1 aPCI slot; 128 MB SDRAM; 512 KB SRAM; CompactFlash slot (type II), ETH 10/100, RS232, 2x USB; battery; metal housing, IP65 protection (front side); 24 VDC.	845
4PP420.1043-75	Power Panel PP420, 10.4" VGA color TFT display with touch screen (resistive); 1 aPCI slot; 128 MB SDRAM; 512 KB SRAM; CompactFlash slot (type II), ETH 10/100, RS232, 2x USB; battery; metal housing, IP65 protection (front side); 24 VDC.	846
4PP420.1043-B5	Power Panel PP420, 10.4" VGA color TFT display with touch screen (resistive); 2 aPCI slots; 128 MB SDRAM; 512 KB SRAM; CompactFlash slot (type II), ETH 10/100, RS232, 2x USB; battery; metal housing, IP65 protection (front side); 24 VDC.	846
4PP420.1505-75	Power Panel PP420, 15" XGA color TFT display with touch screen (resistive); 1 aPCI slot; 128 MB SDRAM; 512 KB SRAM; CompactFlash slot (type II), ETH 10/100, RS232, 2x USB; battery; metal housing, IP65 protection (front side); 24 VDC.	847
4PP420.1505-B5	Power Panel PP420, 15" XGA color TFT display with touch screen (resistive); 2 aPCI slots; 128 MB SDRAM; 512 KB SRAM; CompactFlash slot (type II), ETH 10/100, RS232, 2x USB; battery; metal housing, IP65 protection (front side); 24 VDC.	847
4PP451.0571-45	Power Panel PP451, 5.7" QVGA monochrome LC display; 6 soft keys; 16 function keys and 20 system keys; 1 aPCI slot, 128 MB SDRAM; 512 KB SRAM; CompactFlash slot (type II), ETH 10/100, RS232, 2x USB; battery; metal housing, IP65 protection (front side); 24 VDC.	848
4PP451.0571-75	Power Panel PP451, 5.7" QVGA color TFT display; 6 soft keys; 16 function keys and 20 system keys; 1 aPCI slot, 128 MB SDRAM; 512 KB SRAM; CompactFlash slot (type II), ETH 10/100, RS232, 2x USB; battery; metal housing, IP65 protection (front side); 24 VDC.	849
4PP451.0571-85	Power Panel PP451, 5.7" QVGA monochrome LC display; 6 soft keys; 16 function keys and 20 system keys; 2 aPCI slot, 128 MB SDRAM; 512 KB SRAM; CompactFlash slot (type II), ETH 10/100, RS232, 2x USB; battery; metal housing, IP65 protection (front side); 24 VDC. 4PP451.0571-B5	848
4PP451.0571-B5	Power Panel PP451, 5.7" QVGA color TFT display; 6 soft keys; 16 function keys and 20 system keys; 2 aPCI slot, 128 MB SDRAM; 512 KB SRAM; CompactFlash slot (type II), ETH 10/100, RS232, 2x USB; battery; metal housing, IP65 protection (front side); 24 VDC.	849
4PP451.1043-75	Power Panel PP451, 10.4" VGA color TFT display; 10 soft keys; 28 function keys and 20 system keys; 1 aPCI slot, 128 MB SDRAM; 512 KB SRAM; CompactFlash slot (type II), ETH 10/100, RS232, 2x USB; battery; metal housing, IP65 protection (front side); 24 VDC.	854
4PP451.1043-B5	Power Panel PP451, 10.4" VGA color TFT display; 10 soft keys; 28 function keys and 20 system keys; 2 aPCI slot, 128 MB SDRAM; 512 KB SRAM; CompactFlash slot (type II), ETH 10/100, RS232, 2x USB; battery; metal housing, IP65 protection (front side); 24 VDC.	854
4PP452.0571-45	Power Panel PP452, 5.7" QVGA monochrome LC display; 20 function keys and 20 system keys; 1 aPCI slot, 128 MB SDRAM; 512 KB SRAM; CompactFlash slot (type II), ETH 10/100, RS232, 2x USB; battery; metal housing, IP65 protection (front side); 24 VDC.	850
4PP452.0571-75	Power Panel PP452, 5.7" QVGA color TFT display; 20 function keys and 20 system keys; 1 aPCI slot, 128 MB SDRAM; 512 KB SRAM; CompactFlash slot (type II), ETH 10/100, RS232, 2x USB; battery; metal housing, IP65 protection (front side); 24 VDC.	851
4PP452.0571-B5	Power Panel PP452, 5.7" QVGA color TFT display; 20 function keys and 20 system keys; 2 aPCI slot, 128 MB SDRAM; 512 KB SRAM; CompactFlash slot (type II), ETH 10/100, RS232, 2x USB; battery; metal housing, IP65 protection (front side); 24 VDC.	851
4PP452.1043-75	Power Panel PP452, 10.4" VGA color TFT display; 44 function keys and 20 system keys; 1 aPCI slot, 128 MB SDRAM; 512 KB SRAM; CompactFlash slot (type II), ETH 10/100, RS232, 2x USB; battery; metal housing, IP65 protection (front side); 24 VDC.	857



Model number	Short description	
4PP480.1043-75	Power Panel PP480, 10.4" VGA color TFT display with touch screen (resistive); 10 soft keys and 12 function keys; 1 aPCI slot; 128 MB SDRAM, 512 KB SRAM; CompactFlash slot (type I), ETH 10/100, RS232, 2x USB; battery; metal housing, IP65 protection (front side); 24 VDC.	852
4PP480.1505-75	Power Panel PP480, 15" XGA color TFT display with touch screen (resistive); 12 soft keys and 20 function keys; 1 aPCI slot; 128 MB SDRAM, 512 KB SRAM; CompactFlash slot (type I), ETH 10/100, RS232, 2x USB; battery; metal housing, IP65 protection (front side); 24 VDC.	853
4PP480.1505-B5	Power Panel PP480, 15" XGA color TFT display; 12 soft keys and 20 function keys; 2 aPCI slot; 128 MB SDRAM, 512 KB SRAM; CompactFlash slot (type I), ETH 10/100, RS232, 2x USB; battery; metal housing, IP65 protection (front side); 24 VDC.	853
4PP481.1043-75	Power Panel PP481, 10.4" VGA color TFT color display with touch screen (resistive); 10 soft keys; 28 function and 20 system keys; 1 aPCI slot; 128 MB SDRAM; 512 KB SRAM; CompactFlash slot (type I), ETH 10/100, RS232, 2x USB; battery; metal housing, IP65 protection (front side); 24 VDC.	855
4PP481.1043-B5	Power Panel PP481, 10.4" VGA color TFT color display with touch screen (resistive); 10 soft keys; 28 function and 20 system keys; 2 aPCI slots; 128 MB SDRAM; 512 KB SRAM; CompactFlash slot (type I), ETH 10/100, RS232, 2x USB; battery; metal housing, IP65 protection (front side); 24 VDC.	855
4PP481.1505-75	Power Panel PP481, 15" XGA color TFT color display with touch screen (resistive); 12 soft keys; 20 function and 92 system keys; 1 aPCI slot; 128 MB SDRAM; 512 KB SRAM; CompactFlash slot (type I), ETH 10/100, RS232, 2x USB; battery; metal housing, IP65 protection (front side); 24 VDC.	856
4PP482.1043-75	Power Panel PP482, 10.4" VGA color TFT display with touch screen (resistive); 44 function keys and 20 system keys; 1 aPCI slot; 128 MB SDRAM; 512 KB SRAM; CompactFlash slot (type I), ETH 10/100, RS232, 2x USB; battery; metal housing, IP65 protection (front side); 24 VDC.	857

# Power Panel PP15



4PP015.0420-01/36



4PP015.C420-01/36  
4PP015.E420-01/36

<b>General information</b>	4PP015.0420-01, 4PP015.C420-01, 4PP015.E420-01		4PP015.0420-36, 4PP015.C420-36, 4PP015.E420-36	
Certification	CE, C-UL-US, GHOST-R		CE, C-UL-US, GHOST-R	
Status indicators	I/O function for each channel, status		I/O function for each channel, status	
<b>Diagnostics</b>				
Status	Yes, with status LED		Yes, with status LED	
I/O function	Yes, with LEDs		Yes, with LEDs	
Interface	Yes, with LEDs		Yes, with LEDs	
<b>Display</b>	4PP015.0420-01, 4PP015.C420-01, 4PP015.E420-01		4PP015.0420-36, 4PP015.C420-36, 4PP015.E420-36	
Type	LCD b/w		LCD b/w	
Resolution	4 x 20 characters		4 x 20 characters	
Background lighting	LED		LED	
Display character set	English / Katakana 4PP015.0420-01 English / Cyrillic 4PP015.C420-01 English / European 4PP015.E420-01		English / Katakana 4PP015.0420-36 English / Cyrillic 4PP015.C420-36 English / European 4PP015.E420-36	
<b>Keys</b>	4PP015.0420-01, 4PP015.C420-01, 4PP015.E420-01		4PP015.0420-36, 4PP015.C420-36, 4PP015.E420-36	
Total keys	16 (12 with LEDs) 4PP015.0420-01 26 (10 with LEDs) 4PP015.C420-01, 4PP015.E420-01		16 (12 with LEDs) 4PP015.0420-36 26 (10 with LEDs) 4PP015.C420-36, 4PP015.E420-36	
<b>System keys</b>	Number block Control keys		Number block Control keys	
Label	10 keys with legend strips		10 keys with legend strips	
<b>Processor</b>	4PP015.0420-01, 4PP015.C420-01, 4PP015.E420-01		4PP015.0420-36, 4PP015.C420-36, 4PP015.E420-36	
Typical instruction cycle time (average value at 70% bit and 30% analog processing)	0.8 $\mu$ s		0.8 $\mu$ s	
<b>Standard memory</b>				
User RAM	300 KB SRAM		300 KB SRAM	
System PROM	448 KB FlashPROM		448 KB FlashPROM	
User PROM	1024 KB FlashPROM		1024 KB FlashPROM	
Data buffering with backup battery	Lithium battery 3 V / 950 mAh		Lithium battery 3 V / 950 mAh	
Hardware watchdog	Yes		Yes	
Voltage monitoring	An NMI is triggered at a supply voltage < 15 VDC.		An NMI is triggered at a supply voltage < 15 VDC.	
Real-time clock	1 s resolution, nonvolatile		1 s resolution, nonvolatile	
System bus for expansions	No		No	
<b>Interfaces</b>	4PP015.0420-01, 4PP015.C420-01, 4PP015.E420-01		4PP015.0420-36, 4PP015.C420-36, 4PP015.E420-36	
<b>IF1 application interface</b>				
Type	RS232		RS232	
Design	9-pin DSUB plug		9-pin DSUB plug	
Electrical isolation	No		No	
Max. baud rate	115.2 kBits/s		115.2 kBits/s	
<b>IF2 application interface</b>				
Type	CAN bus		CAN bus	
Design	9-pin DSUB plug		9-pin DSUB plug	
Electrical isolation	Yes		Yes	
<b>Digital inputs</b>	4PP015.0420-01, 4PP015.C420-01, 4PP015.E420-01		4PP015.0420-36, 4PP015.C420-36, 4PP015.E420-36	
Channels	1-3	4-16	1-3	4-8
Additional functions for inputs	Counter		Counter	
Input circuit	Sink or source		Sink or source	
Rated voltage	24 VDC		24 VDC	
Input current at rated voltage	Approx. 10 mA		Approx. 10 mA	
Input filter	<10 $\mu$ s		<10 $\mu$ s	
<b>Electrical isolation</b>				
Channel - Bus	Yes	Yes	Yes	Yes
Channel - Channel	No	No	No	No
Group isolation	No	No	No	No

<b>Analog inputs</b>	<b>4PP015.0420-01, 4PP015.C420-01, 4PP015.E420-01</b>	<b>4PP015.0420-36, 4PP015.C420-36, 4PP015.E420-36</b>
Number of channels	-	4 differential inputs; 2 of which can be configured individually as temperature inputs
Input	-	±10 V
Digital converter resolution	-	12-bit
Conversion time	-	150 µs for all channels
Input filter		
Hardware	-	Cut-off frequency 10 kHz / attenuation 60 dB
Software	-	-
Output format	-	UINT
Input impedance in signal range	-	20 MΩ
Input circuit	-	IEC 61131-2
Electrical isolation		
Channel - Bus	-	Yes
Channel - Channel	-	No
Group isolation	-	No
<b>Temperature measurement</b>	<b>4PP015.0420-01, 4PP015.C420-01, 4PP015.E420-01</b>	<b>4PP015.0420-36, 4PP015.C420-36, 4PP015.E420-36</b>
Number of channels	-	Up to 2 (depending on the configuration)
Input	-	Resistance measurement using 2-line procedure with constant current feed
Digital converter resolution	-	12-bit
Conversion time	-	150 µs for all channels
Input filter		
Hardware	-	Cut-off frequency 10 kHz / attenuation 60 dB
Software	-	-
Output format	-	UINT
Sensor		Can be set per channel
KTY10-6	-	-50°C to +125°C
PT1000	-	-200°C to +850°C
Resistance measurement range	-	0-4000 Ω
Input circuit	-	IEC 61131-2
Electrical isolation		
Channel - Bus	-	Yes
Channel - Channel	-	No
Group isolation	-	No
<b>Digital outputs</b>	<b>4PP015.0420-01, 4PP015.C420-01, 4PP015.E420-01</b>	<b>4PP015.0420-36, 4PP015.C420-36, 4PP015.E420-36</b>
Amount	16	8
Rated voltage	24 VDC	24 VDC
Rated output current	0.5 A	0.5 A
Total current	8 A	4 A
Output circuit	Source	Source
Output protection	Overload protection, short circuit protection	Overload protection, short circuit protection
Internal protective circuit	VDR	VDR
Electrical isolation		
Channel - Bus	No	No
Channel - Channel	No	No
Group isolation	No	No

# Power Panel PP15

<b>Analog outputs</b>	4PP015.0420-01, 4PP015.C420-01, 4PP015.E420-01	4PP015.0420-36, 4PP015.C420-36, 4PP015.E420-36
Number of channels	-	4
Output	-	±10 V
Digital converter resolution	-	12-bit
Conversion time	-	150 µs for all channels
Power on/off behavior	-	Internal enable relay for boot procedure and errors
Basic accuracy	-	±0.088% at 25°C based on the current output value
Output protection	-	Continuous short circuit protection
<b>Electrical isolation</b>		
Channel - Bus	-	Yes
Channel - Channel	-	No
Group isolation	-	No
<b>Power supply</b>	4PP015.0420-01, 4PP015.C420-01, 4PP015.E420-01	4PP015.0420-36, 4PP015.C420-36, 4PP015.E420-36
Rated voltage	24 VDC	24 VDC
Power consumption	Max. 6 W	Max. 6 W
<b>Environmental conditions</b>	4PP015.0420-01, 4PP015.C420-01, 4PP015.E420-01	4PP015.0420-36, 4PP015.C420-36, 4PP015.E420-36
<b>Temperature</b>		
Operation	0 to +50°C	0 to +50°C
Storage	-20 to +60°C	-20 to +60°C
<b>Relative humidity</b>		
Operation	10 to 90% (non-condensing)	10 to 90% (non-condensing)
Storage	5 to 95% (non-condensing)	5 to 95% (non-condensing)
<b>Mechanics</b>	4PP015.0420-01, 4PP015.C420-01, 4PP015.E420-01	4PP015.0420-36, 4PP015.C420-36, 4PP015.E420-36
Protection type	IP65 (front side)	IP65 (front side)
Outer dimensions (W x H x D [mm])	153 x 120 x 46.1	153 x 120 x 46.1
Weight	0.5 kg	0.5 kg

#### Required accessories

0TB103.9	24 VDC screw clamps	1131
0TB103.91	24 VDC cage clamps	1131
7TB718.9	Accessory, terminal block, 18-pin, screw clamps, 1.5 mm <sup>2</sup>	1141
7TB718.91	Accessory, terminal block, 18-pin, cage clamps, 1.5 mm <sup>2</sup>	1141

#### Optional accessories

0AC201.9 <sup>1)</sup>	Lithium batteries, 5 pcs., 3 V / 950 mAh, button cell	1128
4A0006.00-000 <sup>1)</sup>	Lithium battery, 3 V / 950 mAh, button cell	1128
4A0044.00-000	Set of printable legend strips for the PP15 and PP35	---
7AC911.9	CAN bus connector	1143

<sup>1)</sup> Replacement part



4PP015.E420-101

<b>General information</b>		<b>4PP015.E420-101</b>	
Certification	CE, C-UL-US, GHOST-R		
Status indicators	I/O function for each channel, status		
<b>Diagnostics</b>			
Status	Yes, with status LED		
I/O function	Yes, with LEDs		
Interface	Yes, with LEDs		
<b>Display</b>		<b>4PP015.E420-101</b>	
Type	LCD b/w		
Resolution	4 x 20 characters		
Background lighting	LED		
Display character set	English / European		
<b>Keys</b>		<b>4PP015.E420-101</b>	
Total keys	26 (10 with LEDs)		
System keys	Number block Control keys		
Label	10 keys with legend strips		
<b>Processor</b>		<b>4PP015.E420-101</b>	
Typical instruction cycle time (average value at 70% bit and 30% analog processing)	0.8 $\mu$ s		
<b>Standard memory</b>			
User RAM	300 KB SRAM		
System PROM	448 KB FlashPROM		
User PROM	1984 KB FlashPROM		
Data buffering with backup battery	Lithium battery 3 V / 950 mAh		
Hardware watchdog	Yes		
Voltage monitoring	An NMI is triggered at a supply voltage < 15 VDC.		
Real-time clock	1 s resolution, nonvolatile		
System bus for expansions	No		
<b>Interfaces</b>		<b>4PP015.E420-101</b>	
<b>IF1 application interface</b>			
Type	RS232		
Design	9-pin DSUB plug		
Electrical isolation	No		
Max. baud rate	115.2 kBits/s		
<b>IF2 application interface</b>			
Type	CAN bus		
Design	9-pin DSUB plug		
Electrical isolation	Yes		
<b>Digital inputs</b>		<b>4PP015.E420-101</b>	
Channels	1-3	4-16	
Additional functions for inputs	Counter	-	
Input circuit	Sink or source	Sink or source	
Rated voltage	24 VDC	24 VDC	
Input current at rated voltage	Approx. 10 mA	Approx. 5 mA	
Input filter	< 10 $\mu$ s	< 1 ms	
<b>Electrical isolation</b>			
Channel - Bus	Yes	Yes	
Channel - Channel	No	No	
Group isolation	No	No	

# Power Panel PP15

<b>Digital outputs</b>	<b>4PP015.E420-101</b>
Amount	16
Rated voltage	24 VDC
Rated output current	0.5 A
Total current	8 A
Output circuit	Source
Output protection	Overload protection, short circuit protection
Internal protective circuit	VDR
Electrical isolation	
Channel - Bus	No
Channel - Channel	No
Group isolation	No
<b>Power supply</b>	<b>4PP015.E420-101</b>
Rated voltage	24 VDC
Power consumption	Max. 6 W
<b>Environmental conditions</b>	<b>4PP015.E420-101</b>
Temperature	
Operation	0 to +50°C
Storage	-20 to +60°C
Relative humidity	
Operation	10 to 90% (non-condensing)
Storage	5 to 95% (non-condensing)
<b>Mechanics</b>	<b>4PP015.E420-101</b>
Protection type	IP65 (front side)
Outer dimensions (W x H x D [mm])	153 x 120 x 46.1
Weight	0.5 kg

<b>Required accessories</b>		
0TB103.9	24 VDC screw clamps	1131
0TB103.91	24 VDC cage clamps	1131
7TB718.9	Accessory, terminal block, 18-pin, screw clamps, 1.5 mm <sup>2</sup>	1141
7TB718.91	Accessory, terminal block, 18-pin, cage clamps, 1.5 mm <sup>2</sup>	1141
<b>Optional accessories</b>		
0AC201.9 <sup>1)</sup>	Lithium batteries, 5 pcs., 3 V / 950 mAh, button cell	1128
4A0006.00-000 <sup>1)</sup>	Lithium battery, 3 V / 950 mAh, button cell	1128
4A0044.00-000	Set of printable legend strips for the PP15 and PP35	---
7AC911.9	CAN bus connector	1143

1) Replacement part

# Power Panel PP35



4PP035.0300-01/36



4PP035.E300-01/36

General information	4PP035.0300-01, 4PP035.E300-01	4PP035.0300-36, 4PP035.E300-36
Certification	CE, C-UL-US, GHOST-R	CE, C-UL-US, GHOST-R
Status indicators	I/O function for each channel, status	I/O function for each channel, status
Diagnostics		
Status	Yes, with status LED	Yes, with status LED
I/O function	Yes, with LEDs	Yes, with LEDs
Interface	Yes, with LEDs	Yes, with LEDs
Display	4PP035.0300-01, 4PP035.E300-01	4PP035.0300-36, 4PP035.E300-36
Type	LCD b/w	LCD b/w
Resolution	160 x 80 pixels	160 x 80 pixels
Background lighting	LED	LED
Display character set	European / Cyrillic	European / Cyrillic
Keys	4PP035.0300-01, 4PP035.E300-01	4PP035.0300-36, 4PP035.E300-36
Total keys	16 (12 with LEDs) 4PP035.0300-01 26 (10 with LEDs) 4PP035.E300-01	16 (12 with LEDs) 4PP035.0300-36 26 (10 with LEDs) 4PP035.E300-36
System keys	Number block Control keys	Number block Control keys
Label	10 keys with legend strips	10 keys with legend strips
Processor	4PP035.0300-01, 4PP035.E300-01	4PP035.0300-36, 4PP035.E300-36
Typical instruction cycle time (average value at 70% bit and 30% analog processing)	0.8 $\mu$ s	0.8 $\mu$ s
Standard memory		
User RAM	300 KB SRAM	300 KB SRAM
System PROM	448 KB FlashPROM	448 KB FlashPROM
User PROM	1024 KB FlashPROM	1024 KB FlashPROM
Data buffering with backup battery	Lithium battery 3 V / 950 mAh	Lithium battery 3 V / 950 mAh
Hardware watchdog	Yes	Yes
Voltage monitoring	An NMI is triggered at a supply voltage < 15 VDC.	An NMI is triggered at a supply voltage < 15 VDC.
Real-time clock	1 s resolution, nonvolatile	1 s resolution, nonvolatile
System bus for expansions	No	No
Interfaces	4PP035.0300-01, 4PP035.E300-01	4PP035.0300-36, 4PP035.E300-36
IF1 application interface		
Type	RS232	RS232
Design	9-pin DSUB plug	9-pin DSUB plug
Electrical isolation	No	No
Max. baud rate	115.2 kBits/s	115.2 kBits/s
IF2 application interface		
Type	CAN bus	CAN bus
Design	9-pin DSUB plug	9-pin DSUB plug
Electrical isolation	Yes	Yes
Max. baud rate	500 kBits/s	500 kBits/s
Digital inputs	4PP035.0300-01, 4PP035.E300-01	4PP035.0300-36, 4PP035.E300-36
Channels	1-3	4-16
Additional functionalities for inputs	Counter	Counter
Input circuit	Sink or source	Sink or source
Rated voltage	24 VDC	24 VDC
Input current at rated voltage	Approx. 10 mA	Approx. 5 mA
Input filter	<10 $\mu$ s	<1 ms
Electrical isolation		
Channel - Bus	Yes	Yes
Channel - Channel	No	No
Group isolation	No	No

# Power Panel PP35

<b>Analog inputs</b>		<b>4PP035.0300-01, 4PP035.E300-01</b>	<b>4PP035.0300-36, 4PP035.E300-36</b>
Number of channels	-	-	4 differential inputs, 2 of which can be configured individually as temperature inputs
Input	-	-	±10 V
Digital converter resolution	-	-	12-bit
Conversion time	-	-	150 µs for all channels
Input filter			
Hardware	-	-	Cut-off frequency 10 kHz / attenuation 60 dB
Software	-	-	-
Output format	-	-	UINT
Input impedance in signal range	-	-	20 MΩ
Input circuit	-	-	IEC 61131-2
Electrical isolation			
Channel - Bus	-	-	Yes
Channel - Channel	-	-	No
Group isolation	-	-	No
<b>Temperature measurement</b>		<b>4PP035.0300-01, 4PP035.E300-01</b>	<b>4PP035.0300-36, 4PP035.E300-36</b>
Number of channels	-	-	Up to 2 (depending on the configuration)
Input	-	-	Resistance measurement using 2-line procedure with constant current feed
Digital converter resolution	-	-	12-bit
Conversion time	-	-	150 µs for all channels
Input filter			
Hardware	-	-	Cut-off frequency 10 kHz / attenuation 60 dB
Software	-	-	-
Output format	-	-	UINT
Sensor			Can be set per channel
KTY10-6	-	-	-50°C to +125°C
PT1000	-	-	-200°C to +850°C
Resistance measurement range	-	-	0-4000 Ω
Input circuit	-	-	IEC 61131-2
Electrical isolation			
Channel - Bus	-	-	Yes
Channel - Channel	-	-	No
Group isolation	-	-	No
<b>Digital outputs</b>		<b>4PP035.0300-01, 4PP035.E300-01</b>	<b>4PP035.0300-36, 4PP035.E300-36</b>
Amount	16	16	8
Rated voltage	24 VDC	24 VDC	24 VDC
Rated output current	0.5 A	0.5 A	0.5 A
Total current	8 A	8 A	4 A
Output circuit	Source	Source	Source
Output protection	Overload protection, short circuit protection	Overload protection, short circuit protection	Overload protection, short circuit protection
Internal protective circuit	VDR	VDR	VDR
Electrical isolation			
Channel - Bus	No	No	No
Channel - Channel	No	No	No
Group isolation	No	No	No



<b>Analog outputs</b>	<b>4PP035.0300-01, 4PP035.E300-01</b>	<b>4PP035.0300-36, 4PP035.E300-36</b>
Number of channels	-	4
Output	-	±10 V
Digital converter resolution	-	12-bit
Conversion time	-	150 µs for all channels
Power on/off behavior	-	Internal enable relay for boot procedure and errors
Basic accuracy	-	±0.088% at 25°C based on the current output value
Output protection	-	Continuous short circuit protection
Electrical isolation		
Channel - Bus	-	Yes
Channel - Channel	-	No
Group isolation	-	No
<b>Power supply</b>	<b>4PP035.0300-01, 4PP035.E300-01</b>	<b>4PP035.0300-36, 4PP035.E300-36</b>
Rated voltage	24 VDC	24 VDC
Power consumption	Max. 6 W	Max. 6 W
<b>Environmental conditions</b>	<b>4PP035.0300-01, 4PP035.E300-01</b>	<b>4PP035.0300-36, 4PP035.E300-36</b>
Temperature		
Operation	0 to +50°C	0 to +50°C
Storage	-20 to +60°C	-20 to +60°C
Relative humidity		
Operation	10 to 90% (non-condensing)	10 to 90% (non-condensing)
Storage	5 to 95% (non-condensing)	5 to 95% (non-condensing)
<b>Mechanics</b>	<b>4PP035.0300-01, 4PP035.E300-01</b>	<b>4PP035.0300-36, 4PP035.E300-36</b>
Protection type	IP65 (front side)	IP65 (front side)
Outer dimensions (W x H x D [mm])	153 x 120 x 46.1	153 x 120 x 46.1
Weight	0.5 kg	0.5 kg

<b>Required accessories</b>		
0TB103.9	24 VDC screw clamps	1131
0TB103.91	24 VDC cage clamps	1131
7TB718.9	Accessory, terminal block, 18-pin, screw clamps, 1.5 mm <sup>2</sup>	1141
7TB718.91	Accessory, terminal block, 18-pin, cage clamps, 1.5 mm <sup>2</sup>	1141
<b>Optional accessories</b>		
0AC201.9 <sup>1)</sup>	Lithium batteries, 5 pcs., 3 V / 950 mAh, button cell	1128
4A0006.00-000 <sup>1)</sup>	Lithium battery, 3 V / 950 mAh, button cell	1128
4A0044.00-000	Set of printable legend strips for the PP15 and PP35	---
7AC911.9	CAN bus connector	1143

1) Replacement parts

# Power Panel PP35



4PP035.E300-136

<b>General information</b>		<b>4PP035.E300-136</b>	
Certification	CE, C-UL-US, GHOST-R		
Status indicators	I/O function for each channel, status		
<b>Diagnostics</b>			
Status	Yes, with status LED		
I/O function	Yes, with LEDs		
Interface	Yes, with LEDs		
<b>Display</b>		<b>4PP035.E300-136</b>	
Type	LCD b/w		
Resolution	160 x 80 pixels		
Background lighting	LED		
Display character set	European / Cyrillic		
<b>Keys</b>		<b>4PP035.E300-136</b>	
Total keys	26 (10 with LEDs)		
System keys	Number block Control keys		
Label	10 keys with legend strips		
<b>Processor</b>		<b>4PP035.E300-136</b>	
Typical instruction cycle time (average value at 70% bit and 30% analog processing)	0.8 $\mu$ s		
<b>Standard memory</b>			
User RAM	300 KB SRAM		
System PROM	448 KB FlashPROM		
User PROM	1984 KB FlashPROM		
Data buffering with backup battery	Lithium battery 3 V / 950 mAh		
Hardware watchdog	Yes		
Voltage monitoring	An NMI is triggered at a supply voltage < 15 VDC.		
Real-time clock	1 s resolution, nonvolatile		
System bus for expansions	No		
<b>Interfaces</b>		<b>4PP035.E300-136</b>	
<b>IF1 application interface</b>			
Type	RS232		
Design	9-pin DSUB plug		
Electrical isolation	No		
Max. baud rate	115.2 kBits/s		
<b>IF2 application interface</b>			
Type	CAN bus		
Design	9-pin DSUB plug		
Electrical isolation	Yes		
Max. baud rate	500 kBits/s		
<b>Digital inputs</b>		<b>4PP035.E300-136</b>	
Channels	1-3	4-8	
Additional functionalities for inputs	Counter	-	
Input circuit	Sink or source	Sink or source	
Rated voltage	24 VDC	24 VDC	
Input current at rated voltage	Approx. 10 mA	Approx. 5 mA	
Input filter	<10 $\mu$ s	< 1 ms	
<b>Electrical isolation</b>			
Channel - Bus	Yes	Yes	
Channel - Channel	No	No	
Group isolation	No	No	

<b>Analog inputs</b>	<b>4PP035.E300-136</b>
Number of channels	4 differential inputs, 2 of which can be configured individually as temperature inputs
Input	±10 V
Digital converter resolution	12-bit
Conversion time	150 µs for all channels
Input filter	
Hardware	Cut-off frequency 10 kHz / attenuation 60 dB
Software	-
Output format	UINT
Input impedance in signal range	20 MΩ
Input circuit	IEC 61131-2
Electrical isolation	
Channel - Bus	Yes
Channel - Channel	No
Group isolation	No
<b>Temperature measurement</b>	<b>4PP035.E300-136</b>
Number of channels	Up to 2 (depending on the configuration)
Input	Resistance measurement using 2-line procedure with constant current feed
Digital converter resolution	12-bit
Conversion time	150 µs for all channels
Input filter	
Hardware	Cut-off frequency 10 kHz / attenuation 60 dB
Software	-
Output format	UINT
Sensor	Can be set per channel
KTY10-6	-50°C to +125°C
PT1000	-200°C to +850°C
Resistance measurement range	0-4000 Ω
Input circuit	IEC 61131-2
Electrical isolation	
Channel - Bus	Yes
Channel - Channel	No
Group isolation	No
<b>Digital outputs</b>	<b>4PP035.E300-136</b>
Amount	8
Rated voltage	24 VDC
Rated output current	0.5 A
Total current	4 A
Output circuit	Source
Output protection	Overload protection, short circuit protection
Internal protective circuit	VDR
Electrical isolation	
Channel - Bus	No
Channel - Channel	No
Group isolation	No

# Power Panel PP35

<b>Analog outputs</b>		<b>4PP035.E300-136</b>
Number of channels		4
Output		±10 V
Digital converter resolution		12-bit
Conversion time		150 µs for all channels
Power on/off behavior		Internal enable relay for boot procedure and errors
Basic accuracy		±0.088% at 25°C based on the current output value
Output protection		Continuous short circuit protection
<b>Electrical isolation</b>		
Channel - Bus		Yes
Channel - Channel		No
Group isolation		No
<b>Power supply</b>		<b>4PP035.E300-136</b>
Rated voltage		24 VDC
Power consumption		Max. 6 W
<b>Environmental conditions</b>		<b>4PP035.E300-136</b>
<b>Temperature</b>		
Operation		0 to +50°C
Storage		-20 to +60°C
<b>Relative humidity</b>		
Operation		10 to 90% (non-condensing)
Storage		5 to 95% (non-condensing)
<b>Mechanics</b>		<b>4PP035.E300-136</b>
Protection type		IP65 (front side)
Outer dimensions (W x H x D [mm])		153 x 120 x 46.1
Weight		0.5 kg

<b>Required accessories</b>		
0TB103.9	24 VDC screw clamps	1131
0TB103.91	24 VDC cage clamps	1131
7TB718.9	Accessory, terminal block, 18-pin, screw clamps, 1.5 mm <sup>2</sup>	1141
7TB718.91	Accessory, terminal block, 18-pin, cage clamps, 1.5 mm <sup>2</sup>	1141
<b>Optional accessories</b>		
0AC201.9 <sup>1)</sup>	Lithium batteries, 5 pcs., 3 V / 950 mAh, button cell	1128
4A0006.00-000 <sup>1)</sup>	Lithium battery, 3 V / 950 mAh, button cell	1128
4A0044.00-000	Set of printable legend strips for the PP15 and PP35	
7AC911.9	CAN bus connector	1143

<sup>1)</sup> Replacement parts



# Power Panel PP21



<b>Display</b>	<b>4P0420.00-490</b>
Type	LCD
Resolution	4x20 characters
Background lighting	LED
<b>Keys</b>	<b>4P0420.00-490</b>
Function keys	17, with LED
System keys	Number block
	Control keys
<b>Processor</b>	<b>4P0420.00-490</b>
Additional I/O processor	Handles I/O data points
Typical instruction cycle time	0.5 $\mu$ s (average value at 70% bit and 30% analog processing)
<b>Standard memory</b>	
User RAM	700 KB SRAM
System PROM	600 kB FlashPROM
User PROM	1.4 MB FlashPROM
Data buffering with backup battery	Lithium battery 3 V / 950 mAh
Hardware watchdog	Yes
Voltage monitoring	Internal supply monitored for overvoltage and undervoltage
<b>Peripherals</b>	<b>4P0420.00-490</b>
Real-time clock	1 s resolution, nonvolatile
Status indicators	LEDs
System bus for expansions	No
Slots for B&R 2003 screw-in modules	6
For serial asynchronous communication	3
For TPU	3
For CAN bus communication	1
PC card slot	1
<b>Memory size</b>	
SRAM	Max. 4 MB
FlashPROM	Max. 4 MB
<b>Standard communication interfaces</b>	<b>4P0420.00-490</b>
<b>IF1 application interface</b>	
Type	RS232
Design	9-pin DSUB plug
Electrical isolation	No
Max. baud rate	115.2 kBits/s
<b>IF2 application interface</b>	
Type	CAN bus
Design	9-pin DSUB plug
Electrical isolation	Yes
Max. baud rate	500 kBits/s

<b>Digital inputs</b>	<b>4P0420.00-490</b>
Number of channels	10
Additional functionalities for inputs	4x TPU
Input circuit	Sink
Rated voltage	24 VDC
Input current at rated voltage	Approx. 4 mA
Input filter	<1 ms
Electrical isolation	
Channel - Bus	Yes
Channel - Channel	No
Group isolation	Input group - Output group
<b>Digital outputs</b>	<b>4P0420.00-490</b>
Amount	8 + 1 floating relay contact
Rated voltage	24 VDC
Rated output current	0,4 A
Total current	3.2 A
Output circuit	Source
Output protection	Overload protection
Internal protective circuit	Yes
Electrical isolation	
Channel - Bus	Yes
Channel - Channel	No
Group isolation	Input group - Output group
<b>Power supply</b>	<b>4P0420.00-490</b>
Rated voltage	24 VDC
Power consumption	Max. 20 W
Output power for screw-in modules and PC card interface	10 W
<b>Environmental conditions</b>	<b>4P0420.00-490</b>
Temperature	
Operation	0 to +50°C
Storage	-20 to +60°C
Relative humidity	
Operation	10 to 90% (non-condensing)
Storage	5 to 95% (non-condensing)
<b>Mechanics</b>	<b>4P0420.00-490</b>
Protection type	IP65 (front side)
Outer dimensions (W x H x D [mm])	155 x 190 x 84.4
Weight	1.25 kg

# Power Panel PP41



<b>Display</b>	<b>4P3040.01-490</b>
Type	LCD b/w
Diagonal	5.7"
Resolution	QVGA, 320 x 240 pixels
Brightness	150 cd/m <sup>2</sup>
Half-brightness time	50,000 h
<b>Keys</b>	<b>4P3040.01-490</b>
Function keys	16, with LED
System keys	Number block Cursor keys Control keys
<b>Processor</b>	<b>4P3040.01-490</b>
Additional I/O processor	Handles I/O data points
Typical instruction cycle time	0.5 $\mu$ s (average value at 70% bit and 30% analog processing)
Standard memory	
User RAM	700 KB SRAM
System PROM	600 kB FlashPROM
User PROM	1.4 MB FlashPROM
Data buffering with backup battery	Lithium battery 3 V / 950 mAh
Hardware watchdog	Yes
Voltage monitoring	Internal supply monitored for overvoltage and undervoltage
<b>Peripherals</b>	<b>4P3040.01-490</b>
Real-time clock	1 s resolution, nonvolatile
Status indicators	LEDs
System bus for expansions	Expansion module EX101 1 insert slot For B&R SYSTEM 2005 interface modules
Slots for B&R 2003 screw-in modules	6
For serial asynchronous communication	3
For TPU	3
For CAN bus communication	1
PC card slot	1
Memory size	
SRAM	Max. 4 MB
FlashPROM	Max. 4 MB
<b>Standard communication interfaces</b>	<b>4P3040.01-490</b>
IF1 application interface	
Type	RS232
Design	9-pin DSUB plug
Electrical isolation	No
Max. baud rate	115.2 kBits/s
IF2 application interface	
Type	CAN bus
Design	9-pin DSUB plug
Electrical isolation	Yes
Max. baud rate	500 kBits/s



<b>Digital inputs</b>	<b>4P3040.01-490</b>
Number of channels	10
Additional functionalities for inputs	4x TPU
Input circuit	Sink
Rated voltage	24 VDC
Input current at rated voltage	Approx. 4 mA
Input filter	<1 ms
Electrical isolation	
Channel - Bus	Yes
Channel - Channel	No
Group isolation	Input group - Output group
<b>Digital outputs</b>	<b>4P3040.01-490</b>
Amount	8 + 1 floating relay contact
Rated voltage	24 VDC
Rated output current	0.4 A
Total current	3.2 A
Output circuit	Source
Output protection	Overload protection
Internal protective circuit	Yes
Electrical isolation	
Channel - Bus	Yes
Channel - Channel	No
Group isolation	Input group - Output group
<b>Power supply</b>	<b>4P3040.01-490</b>
Rated voltage	24 VDC
Power consumption	Max. 20 W
Output power for screw-in modules and PC card interface	11 W
<b>Environmental conditions</b>	<b>4P3040.01-490</b>
Temperature	
Operation	0 to +50°C
Storage	-20 to +60°C
Relative humidity	
Operation	10 to 90% (non-condensing)
Storage	5 to 95% (non-condensing)
<b>Mechanics</b>	<b>4P3040.01-490</b>
Protection type	IP65 (front side)
Outer dimensions (W x H x D [mm])	205 x 220 x 110.4
Weight	1.95 kg

## PP21 / PP41 accessories

Required accessories		
7TB712.9	Accessory, terminal block, 12-pin, screw clamps, 1.5 mm <sup>2</sup>	1141
7TB712.91	Accessory, terminal block, 12-pin, cage clamps, 1.5 mm <sup>2</sup>	1141
0AC201.9 <sup>1)</sup>	Lithium batteries, 5 pcs., 3 V / 950 mAh, button cell	1128
4A0006.00-000 <sup>1)</sup>	Lithium battery, 3 V / 950 mAh, button cell	1128
Optional accessories		
0MC111.9-1	PCMCIA accessory, 2 MB FLASH	1127
0MC112.9-1	PCMCIA accessory, 4 MB FLASH	1127
0MC211.9	PCMCIA accessory, 2 MB SRAM	1127
4A0034.00-000	A4 legend strip template, for PP41 (4P3040.01-490) 5 sheets, for 10 devices, with CorelDraw template	
4A0035.00-000	A4 legend strip template, for PP21 (4P0420.00-490) 2 sheets, for 10 devices, with CorelDraw template	
4IF370.7	Power Panel interface module, 1 CAN interface, electrically isolated, network capable, screw-in module	
7AI261.7	2003 analog input module, 1 input for evaluation of a full-bridge strain gauge, 24 bit, screw-in module	
7AI294.7	2003 analog input module, 4 inputs, potentiometer evaluation, 13-bit, screw-in module	
7AI351.70	2003 analog input module, 1 input, ±10 V or 0-20 mA, 12-bit + sign, screw-in module, order 1x TB712 terminal block separately	
7AI354.70	2003 analog input module, 4 inputs, ±10 V, 12-bit + sign, screw-in module, order 1x TB712 terminal block separately	
7AI774.70	2003 analog input module, 4 inputs, 0 to 20 mA, 12-bit, screw-in module, order 1x TB712 terminal block separately	
7AM351.70	2003 analog mixed module, 1 input, ±10 V, 16-bit, 1 output, ±10 V, 16-bit, screw-in module, order 1x TB712 terminal block separately	
7AO352.70	2003 analog output module, 2 outputs, ±10 V or 0 - 20 mA, 12-bit, screw-in module, order 1x TB712 terminal block separately	
7AT324.70	2003 analog input module, 4 temperature inputs (2-line connection), KTY10 to +150°C, KTY84 to +300°C, PT100 to +850°C, PT1000 to +850°C, screw-in module, order 1x TB712 terminal block separately	
7AT352.70	2003 analog input module, 2 inputs, PT100 (3-line connection), up to +850°C, screw-in module, order 1x TB712 terminal block separately	
7AT664.70	2003 analog input module, 4 inputs, thermocouple, up to +1768°C, screw-in module, order 1x TB712 terminal block separately	
7DI135.70	2003 digital input module, 4 inputs 24 VDC, sink, incremental encoder operation: 50 kHz, event counter operation: 100 kHz, 1 comparator output 24 VDC, screw-in module, order 1x TB712 terminal block separately	
7DI138.70	2003 digital input module, 10 inputs 24 VDC, sink, 2 inputs for event counter operation, input frequency 20 kHz, screw-in module, order 1x TB712 terminal block separately	
7DI140.70	2003 digital input module, 10 inputs 24 VDC, sink, 2 inputs for event counter operation or direction-dependent position determination, input frequency 50 kHz, 4 inputs can be used as high-speed inputs (e.g. gate, frequency measurement), screw-in module, order 1x TB712 terminal block separately	
7DO135.70	2003 digital output module, 4 FET outputs 12 to 24 VDC, 0.1 A, screw-in module, order 1x TB712 terminal block separately	
7DO138.70	2003 digital output module, 8 outputs 24 VDC, 0.5 A, short circuit protection, thermal overload protection, screw-in module, order 1x TB712 terminal block separately	
7IF311.7	2003 interface module, 1 RS232 interface, screw-in module	
7IF321.7	2003 interface module, 1 RS485/RS422 interface, electrically isolated, network-capable, screw-in module	
7IF361.70-1	2003 interface module, 1 RS485 interface, electrically isolated and network-capable, transfer protocol: PROFIBUS-DP, screw-in module	
7NC161.7	2003 encoder module, input frequency 100 kHz, incremental or absolute, 32-bit, encoder supply 5 VDC or 24 VDC, screw-in module	

<sup>1)</sup> Replacement part

# Power Panel PP45 5.7" LCD touch screen



<b>Controller</b>	<b>4PP045.0571-042</b>
Processor	ELAN SC520 100 MHz, Intel compatible
Main memory	64 MB DRAM
SRAM	32 KB, battery-buffered
CompactFlash slot	1 slot for Type I CompactFlash card
PP45 compact IF slot	1
Watchdog	Internal system management controller
Power failure logic	System management controller, 10 ms buffer time
Battery	Lithium, 950 mAh, exchanged from the outside
Real-time clock	Battery-buffered
Mode/node switches	2, 16 digits each
<b>Display</b>	<b>4PP045.0571-042</b>
Type	LCD m
Colors	8 shades of gray
Resolution	QVGA, 320 x 240 pixels
Diagonal	5.7"
Brightness	140 cd/m <sup>2</sup>
Half-brightness time	55,000 h
Touch screen	Analog resistive
<b>Keys</b>	<b>4PP045.0571-042</b>
Touch keys	10
<b>Interfaces</b>	<b>4PP045.0571-042</b>
USB	2x USB 2.0, connection type A
Ethernet	RJ45 twisted pair (10 BaseT / 100 BaseT)
X2X	X2X Link master
<b>24 VDC supply</b>	<b>4PP045.0571-042</b>
Input voltage	24 VDC ± 25%
<b>Environmental conditions</b>	<b>4PP045.0571-042</b>
Temperature	
Operation	0 to +50°C
Storage	-20°C to +70°C
Relative humidity	
Operation	10% to 90%, non-condensing
Storage	T ≤ 40°C: 5% to 90%, non-condensing T > 40°C: < 90%, non-condensing
<b>Mechanics</b>	<b>4PP045.0571-042</b>
Protection type	IP65 (front side) / IP20 (back side)
Outer dimensions (W x H x D [mm])	203 x 145 x 55
Weight	0.5 kg

Required accessories		
0AC201.9 <sup>1)</sup>	Lithium batteries, 5 pcs., 3 V / 950 mAh, button cell	1128
4A0006.00-000 <sup>1)</sup>	Lithium battery, 3 V / 950 mAh, button cell	1128
0TB103.9	Plug 24 VDC screw clamp	1131
0TB103.91	Plug 24 VDC cage clamp	1131
	CompactFlash cards	1126

1) Replacement part

# Power Panel

## PP45 5.7" LCD color touch screen



<b>Controller</b>	<b>4PP045.0571-062</b>
Processor	ELAN SC520 100 MHz, Intel compatible
Main memory	64 MB DRAM
SRAM	32 KB, battery-buffered
CompactFlash slot	1 slot for Type I CompactFlash card
PP45 compact IF slot	1
Watchdog	Internal system management controller
Power failure logic	System management controller, 10 ms buffer time
Battery	Lithium, 950 mAh, exchanged from the outside
Real-time clock	Battery-buffered
Mode/node switches	2, 16 digits each
<b>Display</b>	<b>4PP045.0571-062</b>
Type	LCD color
Colors	256 colors
Resolution	QVGA, 320 x 240 pixels
Diagonal	5.7"
Brightness	140 cd/m <sup>2</sup>
Half-brightness time	55,000 h
Touch screen	Analog resistive
<b>Keys</b>	<b>4PP045.0571-062</b>
Touch keys	10
<b>Interfaces</b>	<b>4PP045.0571-062</b>
USB	2x USB 2.0, connection type A
Ethernet	RJ45 twisted pair (10 BaseT / 100 BaseT)
X2X	X2X Link master
<b>24 VDC supply</b>	<b>4PP045.0571-062</b>
Input voltage	24 VDC ± 25%
<b>Environmental conditions</b>	<b>4PP045.0571-062</b>
Temperature	
Operation	0 to +50°C
Storage	-20°C to +70°C
Relative humidity	
Operation	10% to 90%, non-condensing
Storage	T ≤ 40°C: 5% to 90%, non-condensing T > 40°C: < 90%, non-condensing
<b>Mechanics</b>	<b>4PP045.0571-062</b>
Protection type	IP65 (front side) / IP20 (back side)
Outer dimensions (W x H x D [mm])	203 x 145 x 55
Weight	0.5 kg

Required accessories		
0AC201.9 <sup>1)</sup>	Lithium batteries, 5 pcs., 3 V / 950 mAh, button cell	1128
4A0006.00-000 <sup>1)</sup>	Lithium battery, 3 V / 950 mAh, button cell	1128
0TB103.9	Plug 24 VDC screw clamp	1131
0TB103.91	Plug 24 VDC cage clamp	1131
	CompactFlash cards	1126

<sup>1)</sup> Replacement part

# Power Panel PP45 5.7" LCD



<b>Controller</b>	<b>4PP045.0571-L42</b>	
Processor	ELAN SC520 100 MHz, Intel compatible	
Main memory	64 MB DRAM	
SRAM	32 KB, battery-buffered	
CompactFlash slot	1 slot for Type I CompactFlash card	
PP45 compact IF slot	1	
Watchdog	Internal system management controller	
Power failure logic	System management controller, 10 ms buffer time	
Battery	Lithium, 950 mAh, exchanged from the outside	
Real-time clock	Battery-buffered	
Mode/node switches	2, 16 digits each	
<b>Display</b>	<b>4PP045.0571-L42</b>	
Type	LCD b/w	
Colors	8 shades of gray	
Resolution	QVGA, 320 x 240 pixels	
Diagonal	5.7"	
Brightness	140 cd/m <sup>2</sup>	
Half-brightness time	55,000 h	
<b>Keys</b>	<b>4PP045.0571-L42</b>	
Function keys	24 (6 with legend strips)	
<b>Interfaces</b>	<b>4PP045.0571-L42</b>	
Ethernet	RJ45 twisted pair (10 BaseT / 100 BaseT)	
X2X	X2X Link master	
<b>24 VDC supply</b>	<b>4PP045.0571-L42</b>	
Input voltage	24 VDC ± 25%	
<b>Environmental conditions</b>	<b>4PP045.0571-L42</b>	
Temperature		
Operation	0 to +50°C	
Storage	-20°C to +70°C	
Relative humidity		
Operation	10% to 90%, non-condensing	
Storage	T ≤ 40°C: 5% to 90%, non-condensing T > 40°C: < 90%, non-condensing	
<b>Mechanics</b>	<b>4PP045.0571-L42</b>	
Protection type	IP65 (front side) / IP20 (back side)	
Outer dimensions (W x H x D [mm])	203 x 145 x 55	
Weight	0.5 kg	

Required accessories		
0AC201.9 <sup>1)</sup>	Lithium batteries, 5 pcs., 3 V / 950 mAh, button cell	1128
4A0006.00-000 <sup>1)</sup>	Lithium battery, 3 V / 950 mAh, button cell	1128
0TB103.9	Plug 24 VDC screw clamp	1131
0TB103.91	Plug 24 VDC cage clamp	1131
	CompactFlash cards	1126

<sup>1)</sup> Replacement part

# PP45 interface module IF10



<b>Short description</b>	4PP045.IF10-1
Communication module	1x RS232
<b>Interfaces</b>	4PP045.IF10-1
<b>Interface</b>	
Type	RS232
Design	9-pin DSUB plug
Maximum transfer rate	115.2 kBit/s
<b>General information</b>	4PP045.IF10-1
Status indicators	Sending and receiving data
<b>Diagnostics</b>	
Data transfer	Yes, with status LEDs
<b>Electrical isolation</b>	
PLC - IF1	No
<b>Power consumption</b>	
3.3 V	0.15 W
5 V	1.2 W
Total	1.35 W
Certification	CE, C-UL-US, GOST-R
<b>Mechanical characteristics</b>	4PP045.IF10-1
Slot	PP45 insert
Protection type	IP20
Operating / Storage temperature	0°C to + 50°C / - 25°C to + 70°C
Relative humidity	10 to 90%, non-condensing

<b>Optional accessories</b>	
0G001.00-090	Cable PC <-> PLC/PW, RS232, online cable

# PP45 interface module IF23



<b>Short description</b>	<b>4PP045.IF23-1</b>	
Communication module	1x RS232/RS422/RS485, 1x CAN	
<b>Interfaces</b>	<b>4PP045.IF23-1</b>	
<b>Interface IF1</b>		
Type	RS232	
Design	9-pin DSUB plug (shared with IF2)	
Maximum transfer rate	115.2 kBit/s	
<b>Interface IF2</b>		
Type	RS485/RS422	
Design	9-pin DSUB plug (shared with IF1)	
Maximum transfer rate	115.2 kBit/s	
<b>Interface IF3</b>		
Type	CAN	
Design	4-pin multipoint connector	
Maximum transfer rate	1000 kBit/s	
<b>General information</b>	<b>4PP045.IF23-1</b>	
Status indicators	Send/receive data via interface	
<b>Diagnostics</b>		
Data transfer	Yes, with status LED	
<b>Electrical isolation</b>		
PLC - IF1	No	
PLC - IF2/IF3	Yes	
IF1 - IF2/IF3	Yes	
IF2 - IF3	Yes	
<b>Power consumption</b>		
5 V	2.0 W	
24 V	-	
Total	2.0 W	
Certification	CE, C-UL-US, GOST-R	
<b>Mechanical characteristics</b>	<b>4PP045.IF23-1</b>	
Slot	PP45 insert	
Protection type	IP20	
Operating / Storage temperature	0°C to + 50°C / - 25°C to + 70°C	
Relative humidity	10 to 90%, non-condensing	

<b>Optional accessories</b>		
0AC913.93	Bus adapter, CAN, 2 CAN interfaces, including 30 cm attachment cable (TB704)	▮ 1141
0G0001.00-090	Cable PC <-> PLC/PW, RS232, online cable	
0G1000.00-090	Bus connector, RS485, for Profibus networks	▮ 1141

# PP45 interface module IF24



<b>Short description</b>	<b>4PP045.IF24-1</b>
Communication module	1x RS232/RS422/RS485, 1x Profibus DP slave
<b>Interfaces</b>	<b>4PP045.IF24-1</b>
<b>Interface IF1</b>	
Type	RS232
Design	9-pin DSUB plug (shared with IF2)
Maximum transfer rate	115.2 kBit/s
<b>Interface IF2</b>	
Type	RS485/RS422
Design	9-pin DSUB socket (shared with IF1)
Maximum transfer rate	115.2 kBit/s
<b>Interface IF3</b>	
Fieldbus	Profibus DP slave
Type	RS485
Design	9-pin DSUB socket
Maximum transfer rate	12 MBit/s
<b>General information</b>	<b>4PP045.IF24-1</b>
Status indicators	Send/receive data via interface
<b>Diagnostics</b>	
Data transfer	Yes, with status LED
<b>Electrical isolation</b>	
PLC - IF1	No
PLC - IF2	Yes
PLC - IF3	Yes
<b>Power consumption</b>	
3.3 V	0.15 W
5 V	1.2 W
Total	1.35 W
Certification	CE, C-UL-US, GOST-R
<b>Mechanical characteristics</b>	<b>4PP045.IF24-1</b>
Slot	PP45 insert
Protection type	IP20
Operating / Storage temperature	0°C to + 50°C / - 25°C to + 70°C
Relative humidity	10 to 90%, non-condensing

<b>Optional accessories</b>		
0G0001.00-090	Cable PC <-> PLC/PW, RS232, online cable	
0G1000.00-090	Bus connector, RS485, for Profibus networks	1141



# PP45 interface module IF33



<b>Short description</b>	4PP045.IF33-1	
Communication module	2x CAN bus	
<b>Interfaces</b>	4PP045.IF33-1	
Interfaces IF1 and IF2		
Type	CAN bus	
Design	2x 4-pin multipoint connector	
Maximum transfer rate	1000 kBit/s	
<b>General information</b>	4PP045.IF33-1	
Status indicators	2 LEDs each for sending/receiving data for IF1 and IF2	
Diagnostics		
Data transfer	Yes, with status LEDs	
Electrical isolation		
PLC - IF1/IF2	Yes	
IF1 - IF2	Yes	
Power consumption		
3.3 V	0.2 W	
5 V	1.8 W	
Total	2.0 W	
Certification	CE, C-UL-US, GOST-R	
<b>Mechanical characteristics</b>	4PP045.IF33-1	
Slot	PP45 insert	
Protection type	IP20	
Operating / Storage temperature	0°C to + 50°C / - 25°C to + 70°C	
Relative humidity	10 to 90%, non-condensing	

<b>Required accessories</b>		
0TB704.9	Accessory terminal block, 4-pin, screw clamp, 1.5 mm <sup>2</sup>	1134
<b>Optional accessories</b>		
0AC913.93	Bus adapter, CAN, 2 CAN interfaces, including 30 cm attachment cable (TB704)	1141

# Power Panel

## PP320 Bios 5.7" TFT color touch screen



<b>Controller</b>	<b>5PP320.0571-39</b>
Processor	Geode LX800 500 MHz, MMX compatible
Main memory	256 MB DRAM
Graphics memory	8 MB shared memory (allocated from main memory)
CompactFlash slot	1 slot for Type I CompactFlash card
Battery	Lithium, 950 mAh, exchanged from the outside
Real-time clock	Battery-buffered
Mode/node switches	2, 16 digits each
<b>Display</b>	<b>5PP320.0571-39</b>
Type	TFT color
Colors	262.144 <sup>1)</sup>
Resolution	QVGA, 320 x 240 pixels
Diagonal	5.7"
Brightness	500 cd/m <sup>2</sup>
Half-brightness time	50,000 h
Touch screen	Analog resistive
1) The actual number of colors depends on the graphics memory, the graphics mode configured, and the graphics driver being used.	
<b>Interfaces</b>	<b>5PP320.0571-39</b>
<b>Serial</b>	
Type	RS232
Design	9-pin DSUB plug
Electrical isolation	No
Max. baud rate	115 kBits/s
USB	2x USB 1.1, 2.0, connection type A <sup>1)</sup>
Ethernet	RJ45 twisted pair (10 BaseT / 100 BaseT)
1) Windows CE limitation - USB 1.1	
<b>24 VDC supply</b>	<b>5PP320.0571-39</b>
Input voltage	24 VDC ±25%, electrically isolated
<b>Environmental conditions</b>	<b>5PP320.0571-39</b>
<b>Temperature</b>	
Operation	0 to +50°C
Storage	-20°C to +60°C
<b>Relative humidity</b>	
Operation	5% to 85%, non-condensing
Storage	T ≤ 40°C: 5% to 90%, non-condensing T > 40°C: < 90%, non-condensing
<b>Mechanics</b>	<b>5PP320.0571-39</b>
Protection type	IP65 (front side) / IP20 (back side)
Outer dimensions (W x H x D [mm])	212 x 156 x 55.5
Weight	1.4 kg

Required accessories		
0AC201.9 <sup>1)</sup>	Lithium batteries, 5 pcs., 3 V / 950 mAh, button cell	1128
4A0006.00-000 <sup>1)</sup>	Lithium battery, 3 V / 950 mAh, button cell	1128
0TB103.9	Plug 24 VDC screw clamp	1131
0TB103.91	Plug 24 VDC cage clamp	1131
	Operating system	1114
	CompactFlash cards	1126

1) Replacement part



# Power Panel PP320 Bios 5.7" TFT color touch screen



	5PP320.0573-39	5PP320.0573-3B
<b>Controller</b>	5PP320.0573-39	5PP320.0573-3B
Processor	Geode LX800 500 MHz, MMX compatible	Geode LX800 500 MHz, MMX compatible
Main memory	256 MB DRAM	512 MB DRAM
Graphics memory	8 MB shared memory (allocated from main memory)	8 MB shared memory (allocated from main memory)
CompactFlash slot	1 slot for Type I CompactFlash card	1 slot for Type I CompactFlash card
Battery	Lithium, 950 mAh, exchanged from the outside	Lithium, 950 mAh, exchanged from the outside
Real-time clock	Battery-buffered	Battery-buffered
Mode/node switches	2, 16 digits each	2, 16 digits each
<b>Display</b>	5PP320.0573-39	5PP320.0573-3B
Type	TFT color	TFT color
Colors	262,144 <sup>1)</sup>	262,144 <sup>1)</sup>
Resolution	VGA, 640 x 480 pixels	VGA, 640 x 480 pixels
Diagonal	5.7"	5.7"
Brightness	350 cd/m <sup>2</sup>	350 cd/m <sup>2</sup>
Half-brightness time	75,000 h	75,000 h
Touch screen	Analog resistive	Analog resistive
<small>1) The actual number of colors depends on the graphics memory, the graphics mode configured, and the graphics driver being used.</small>		
<b>Interfaces</b>	5PP320.0573-39	5PP320.0573-3B
<b>Serial</b>		
Type	RS232	RS232
Design	9-pin DSUB plug	9-pin DSUB plug
Electrical isolation	No	No
Max. baud rate	115 kBits/s	115 kBits/s
<b>USB</b>	2x USB 1.1, 2.0, connection type A <sup>1)</sup>	2x USB 1.1, 2.0, connection type A <sup>1)</sup>
<b>Ethernet</b>	RJ45 twisted pair (10 BaseT / 100 BaseT)	RJ45 twisted pair (10 BaseT / 100 BaseT)
<small>1) Windows CE limitation - USB 1.1</small>		
<b>24 VDC supply</b>	5PP320.0573-39	5PP320.0573-3B
Input voltage	24 VDC ±25%, electrically isolated	24 VDC ±25%, electrically isolated
<b>Environmental conditions</b>	5PP320.0573-39	5PP320.0573-3B
<b>Temperature</b>		
Operation	0 to +50°C	0 to +50°C
Storage	-20°C to +60°C	-20°C to +60°C
<b>Relative humidity</b>		
Operation	5% to 85%, non-condensing	5% to 85%, non-condensing
Storage	T <= 40°C: 5% to 90%, non-condensing T > 40°C: < 90%, non-condensing	T <= 40°C: 5% to 90%, non-condensing T > 40°C: < 90%, non-condensing
<b>Mechanics</b>	5PP320.0573-39	5PP320.0573-3B
Protection type	IP65 (front side) / IP20 (back side)	IP65 (front side) / IP20 (back side)
Outer dimensions (W x H x D [mm])	212 x 156 x 55.5	212 x 156 x 55.5
Weight	1.4 kg	1.4 kg

Required accessories		
0AC201.9 <sup>1)</sup>	Lithium batteries, 5 pcs., 3 V / 950 mAh, button cell	1128
4A0006.00-000 <sup>1)</sup>	Lithium battery, 3 V / 950 mAh, button cell	1128
0TB103.9	Plug 24 VDC screw clamp	1131
0TB103.91	Plug 24 VDC cage clamp	1131
	Operating system	1114
	CompactFlash cards	1126

1) Replacement part

# Power Panel PP320 Bios 10.4" TFT color touch screen



<b>Controller</b>	<b>5PP320.1043-39</b>
Processor	Geode LX800 500 MHz, MMX compatible
Main memory	256 MB DRAM
Graphics memory	8 MB shared memory (allocated from main memory)
CompactFlash slot	1 slot for Type I CompactFlash card
Battery	Lithium, 950 mAh, exchanged from the outside
Real-time clock	Battery-buffered
Mode/node switches	2, 16 digits each
<b>Display</b>	<b>5PP320.1043-39</b>
Type	TFT color
Colors	262.144 <sup>1)</sup>
Resolution	VGA, 640 x 480 pixels
Diagonal	10.4"
Brightness	450 cd/m <sup>2</sup>
Half-brightness time	55,000 h
Touch screen	Analog resistive
<sup>1)</sup> The actual number of colors depends on the graphics memory, the graphics mode configured, and the graphics driver being used.	
<b>Interfaces</b>	<b>5PP320.1043-39</b>
<b>Serial</b>	
Type	RS232
Design	9-pin DSUB plug
Electrical isolation	No
Max. baud rate	115 kBits/s
USB	2x USB 1.1, 2.0, connection type A <sup>1)</sup>
Ethernet	RJ45 twisted pair (10 BaseT / 100 BaseT)
<sup>1)</sup> Windows CE limitation - USB 1.1	
<b>24 VDC supply</b>	<b>5PP320.1043-39</b>
Input voltage	24 VDC ±25%, electrically isolated
<b>Environmental conditions</b>	<b>5PP320.1043-39</b>
<b>Temperature</b>	
Operation	0 to +50°C
Storage	-20°C to +70°C
<b>Relative humidity</b>	
Operation	5% to 85%, non-condensing
Storage	T ≤ 40°C: 5% to 90%, non-condensing T > 40°C: < 90%, non-condensing
<b>Mechanics</b>	<b>5PP320.1043-39</b>
Protection type	IP65 (front side) / IP20 (back side)
Outer dimensions (W x H x D [mm])	323 x 260 x 65.5
Weight	3.7 kg

Required accessories		
0AC201.9 <sup>1)</sup>	Lithium batteries, 5 pcs., 3 V / 950 mAh, button cell	1128
4A0006.00-000 <sup>1)</sup>	Lithium battery, 3 V / 950 mAh, button cell	1128
0TB103.9	Plug 24 VDC screw clamp	1131
0TB103.91	Plug 24 VDC cage clamp	1131
	Operating system	1114
	CompactFlash cards	1126

<sup>1)</sup> Replacement part

# Power Panel

## PP320 Bios 12.1" TFT color touch screen



<b>Controller</b>	<b>5PP320.1214-39</b>	
Processor	Geode LX800 500 MHz, MMX compatible	
Main memory	256 MB DRAM	
Graphics memory	8 MB shared memory (allocated from main memory)	
CompactFlash slot	1 slot for Type I CompactFlash card	
Battery	Lithium, 950 mAh, exchanged from the outside	
Real-time clock	Battery-buffered	
Mode/node switches	2, 16 digits each	
<b>Display</b>	<b>5PP320.1214-39</b>	
Type	TFT color	
Colors	262.144 <sup>1)</sup>	
Resolution	SVGA, 800 x 600 pixels	
Diagonal	12.1"	
Brightness	350 cd/m <sup>2</sup>	
Half-brightness time	50,000 h	
Touch screen	Analog resistive	
<small>1) The actual number of colors depends on the graphics memory, the graphics mode configured, and the graphics driver being used.</small>		
<b>Interfaces</b>	<b>5PP320.1214-39</b>	
Serial		
Type	RS232	
Design	9-pin DSUB plug	
Electrical isolation	No	
Max. baud rate	115 kBits/s	
USB	2x USB 1.1, 2.0, connection type A <sup>1)</sup>	
Ethernet	RJ45 twisted pair (10 BaseT / 100 BaseT)	
<small>1) Windows CE limitation - USB 1.1</small>		
<b>24 VDC supply</b>	<b>5PP320.1214-39</b>	
Input voltage	24 VDC ±25%, electrically isolated	
<b>Environmental conditions</b>	<b>5PP320.1214-39</b>	
Temperature		
Operation	0 to +45°C	
Storage	-20°C to +60°C	
Relative humidity		
Operation	5% to 85%, non-condensing	
Storage	T ≤ 40°C: 5% to 90%, non-condensing T > 40°C: < 90%, non-condensing	
<b>Mechanics</b>	<b>5PP320.1214-39</b>	
Protection type	IP65 (front side) / IP20 (back side)	
Outer dimensions (W x H x D [mm])	362 x 284 x 65.5	
Weight	4.1 kg	

Required accessories		
0AC201.9 <sup>1)</sup>	Lithium batteries, 5 pcs., 3 V / 950 mAh, button cell	1128
4A0006.00-000 <sup>1)</sup>	Lithium battery, 3 V / 950 mAh, button cell	1128
0TB103.9	Plug 24 VDC screw clamp	1131
0TB103.91	Plug 24 VDC cage clamp	1131
	Operating system	1114
	CompactFlash cards	1126

1) Replacement part

# Power Panel PP320 Bios 15" TFT color touch screen



<b>Controller</b>	<b>5PP320.1505-39</b>
Processor	Geode LX800 500 MHz, MMX compatible
Main memory	256 MB DRAM
Graphics memory	8 MB shared memory (allocated from main memory)
CompactFlash slot	1 slot for Type I CompactFlash card
Battery	Lithium, 950 mAh, exchanged from the outside
Real-time clock	Battery-buffered
Mode/node switches	2, 16 digits each
<b>Display</b>	<b>5PP320.1505-39</b>
Type	TFT color
Colors	262.144 <sup>1)</sup>
Resolution	XGA, 1024 x 768 pixels
Diagonal	15"
Brightness	250 cd/m <sup>2</sup>
Half-brightness time	50,000 h
Touch screen	Analog resistive
<sup>1)</sup> The actual number of colors depends on the graphics memory, the graphics mode configured, and the graphics driver being used.	
<b>Interfaces</b>	<b>5PP320.1505-39</b>
<b>Serial</b>	
Type	RS232
Design	9-pin DSUB plug
Electrical isolation	No
Max. baud rate	115 kBits/s
USB	2x USB 1.1, 2.0, connection type A <sup>1)</sup>
Ethernet	RJ45 twisted pair (10 BaseT / 100 BaseT)
<sup>1)</sup> Windows CE limitation - USB 1.1	
<b>24 VDC supply</b>	<b>5PP320.1505-39</b>
Input voltage	24 VDC ±25%, electrically isolated
<b>Environmental conditions</b>	<b>5PP320.1505-39</b>
<b>Temperature</b>	
Operation	0°C to +50°C
Storage	-20°C to +60°C
<b>Relative humidity</b>	
Operation	5% to 85%, non-condensing
Storage	T ≤ 40°C: 5% to 90%, non-condensing T > 40°C: < 90%, non-condensing
<b>Mechanics</b>	<b>5PP320.1505-39</b>
Protection type	IP65 (front side) / IP20 (back side)
Outer dimensions (W x H x D [mm])	435 x 330 x 71.5
Weight	6.3 kg

Required accessories		
0AC201.9 <sup>1)</sup>	Lithium batteries, 5 pcs., 3 V / 950 mAh, button cell	1128
4A0006.00-000 <sup>1)</sup>	Lithium battery, 3 V / 950 mAh, button cell	1128
0TB103.9	Plug 24 VDC screw clamp	1131
0TB103.91	Plug 24 VDC cage clamp	1131
	Operating system	1114
	CompactFlash cards	1126

<sup>1)</sup> Replacement part

# Power Panel

## PP320 embedded 5.7" LCD monochrome touch screen



<b>Controller</b>	<b>4PP320.0571-01</b>
Processor	Geode LX800 500 MHz, MMX compatible
Main memory	128 MB DRAM
Graphics memory	8 MB shared memory (allocated from main memory)
CompactFlash slot	1 slot for Type I CompactFlash card
Mode/node switches	2, 16 digits each
<b>Display</b>	<b>4PP320.0571-01</b>
Type	LCD monochrome
Colors	8 shades of grey <sup>1)</sup>
Resolution	QVGA, 320 x 240 pixels
Diagonal	5.7"
Brightness	220 cd/m <sup>2</sup>
Half-brightness time	50,000 h
Touch screen	Analog resistive
1) Automation Runtime limitation - max. 256 shades of grey, USB 1.1	
<b>Interfaces</b>	<b>4PP320.0571-01</b>
Serial	
Type	RS232
Design	9-pin DSUB plug
Electrical isolation	No
Max. baud rate	115 kBits/s
USB	2x USB 2.0, connection type A <sup>1)</sup>
Ethernet	RJ45 twisted pair (10 BaseT / 100 BaseT)
1) Automation Runtime limitation - max. 256 shades of grey, USB 1.1	
<b>24 VDC supply</b>	<b>4PP320.0571-01</b>
Input voltage	24 VDC ±25%, electrically isolated
<b>Environmental conditions</b>	<b>4PP320.0571-01</b>
Ambient temperature	
Operation	0 to 50°C
Storage	-20 to +60°C
Relative humidity	
Operation	5 - 85%, non-condensing
Storage	T ≤ 40°C: 5% to 90%, non-condensing T > 40°C: < 90%, non-condensing
<b>Mechanics</b>	<b>4PP320.0571-01</b>
Protection type	IP65 (front side) / IP20 (back side)
Outer dimensions (W x H x D [mm])	212 x 156 x 55.5
Weight	1.4 kg

Required accessories		
0TB103.9	Plug 24 VDC screw clamp	▣ 1131
0TB103.91	Plug 24 VDC cage clamp	▣ 1131
	CompactFlash cards	▣ 1126



# Power Panel PP320 embedded 5.7" TFT touch screen



<b>Controller</b>		<b>4PP320.0571-35</b>
Processor	Geode LX800 500 MHz, MMX compatible	
Main memory	128 MB DRAM	
Graphics memory	8 MB shared memory (allocated from main memory)	
CompactFlash slot	1 slot for Type I CompactFlash card	
Mode/node switches	2, 16 digits each	
<b>Display</b>		<b>4PP320.0571-35</b>
Type	TFT color	
Colors	262.144 <sup>1)</sup>	
Resolution	QVGA, 320 x 240 pixels	
Diagonal	5.7"	
Brightness	500 cd/m <sup>2</sup>	
Half-brightness time	50,000 h	
Touch screen	Analog resistive	
1) Automation Runtime limitation - max. 256 colors, USB 1.1		
<b>Interfaces</b>		<b>4PP320.0571-35</b>
<b>Serial</b>		
Type	RS232	
Design	9-pin DSUB plug	
Electrical isolation	No	
Max. baud rate	115 kBits/s	
<b>USB</b>		
USB	2x USB 2.0, connection type A <sup>1)</sup>	
Ethernet	RJ45 twisted pair (10 BaseT / 100 BaseT)	
1) Automation Runtime limitation - max. 256 colors, USB 1.1		
<b>24 VDC supply</b>		<b>4PP320.0571-35</b>
Input voltage	24 VDC ±25%, electrically isolated	
<b>Environmental conditions</b>		<b>4PP320.0571-35</b>
<b>Ambient temperature</b>		
Operation	0 to 50°C	
Storage	-20 to +60°C	
<b>Relative humidity</b>		
Operation	5 - 85%, non-condensing	
Storage	T ≤ 40°C: 5% to 90%, non-condensing T > 40°C: < 90%, non-condensing	
<b>Mechanics</b>		<b>4PP320.0571-35</b>
Protection type	IP65 (front side) / IP20 (back side)	
Outer dimensions (W x H x D [mm])	212 x 156 x 55.5	
Weight	1.4 kg	

<b>Required accessories</b>		
0TB103.9	Plug 24 VDC screw clamp	▣ 1131
0TB103.91	Plug 24 VDC cage clamp	▣ 1131
	CompactFlash cards	▣ 1126

# Power Panel PP320 embedded 10.4" TFT color touch screen



<b>Controller</b>		<b>4PP320.1043-31</b>
Processor	Geode LX800 500 MHz, MMX compatible	
Main memory	128 MB DRAM	
Graphics memory	8 MB shared memory (allocated from main memory)	
CompactFlash slot	1 slot for Type I CompactFlash card	
Mode/node switches	2, 16 digits each	
<b>Display</b>		<b>4PP320.1043-31</b>
Type	TFT color	
Colors	262.144 <sup>1)</sup>	
Resolution	VGA, 640 x 480 pixels	
Diagonal	10.4"	
Brightness	450 cd/m <sup>2</sup>	
Half-brightness time	55,000 h	
Touch screen	Analog resistive	
1) Automation Runtime limitation - max. 256 colors, USB 1.1		
<b>Interfaces</b>		<b>4PP320.1043-31</b>
<b>Serial</b>		
Type	RS232	
Design	9-pin DSUB plug	
Electrical isolation	No	
Max. baud rate	115 kBits/s	
<b>USB</b>		
USB	2x USB 2.0, connection type A <sup>1)</sup>	
Ethernet	RJ45 twisted pair (10 BaseT / 100 BaseT)	
1) Automation Runtime limitation - max. 256 colors, USB 1.1		
<b>24 VDC supply</b>		<b>4PP320.1043-31</b>
Input voltage	24 VDC ±25%, electrically isolated	
<b>Environmental conditions</b>		<b>4PP320.1043-31</b>
<b>Temperature</b>		
Operation	0 to 50°C	
Storage	-20 to +70°C	
<b>Relative humidity</b>		
Operation	5 - 85%, non-condensing	
Storage	T ≤ 40°C: 5% to 90%, non-condensing T > 40°C: < 90%, non-condensing	
<b>Mechanics</b>		<b>4PP320.1043-31</b>
Protection type	IP65 (front side) / IP20 (back side)	
Outer dimensions (W x H x D [mm])	323 x 260 x 65.5	
Weight	3.7 kg	

<b>Required accessories</b>		
0TB103.9	Plug 24 VDC screw clamp	▣ 1131
0TB103.91	Plug 24 VDC cage clamp	▣ 1131
	CompactFlash cards	▣ 1126

# Power Panel PP320 embedded 15" TFT color touch screen



<b>Controller</b>		<b>4PP320.1505-31</b>
Processor	Geode LX800 500 MHz, MMX compatible	
Main memory	128 MB DRAM	
Graphics memory	8 MB shared memory (allocated from main memory)	
CompactFlash slot	1 slot for Type I CompactFlash card	
Mode/node switches	2, 16 digits each	
<b>Display</b>		<b>4PP320.1505-31</b>
Type	TFT color	
Colors	262.144 <sup>1)</sup>	
Resolution	XGA, 1024 x 768 pixels	
Diagonal	15"	
Brightness	250 cd/m <sup>2</sup>	
Half-brightness time	50,000 h	
Touch screen	Analog resistive	
1) Automation Runtime limitation - max. 256 colors, USB 1.1		
<b>Interfaces</b>		<b>4PP320.1505-31</b>
Serial		
Type	RS232	
Design	9-pin DSUB plug	
Electrical isolation	No	
Max. baud rate	115 kBits/s	
USB	2x USB 2.0, connection type A <sup>1)</sup>	
Ethernet	RJ45 twisted pair (10 BaseT / 100 BaseT)	
1) Automation Runtime limitation - max. 256 colors, USB 1.1		
<b>24 VDC supply</b>		<b>4PP320.1505-31</b>
Input voltage	24 VDC ±25%, electrically isolated	
<b>Environmental conditions</b>		<b>4PP320.1505-31</b>
Temperature		
Operation	0°C to +50°C	
Storage	-20 to +60°C	
Relative humidity		
Operation	5 - 85%, non-condensing	
Storage	T ≤ 40°C: 5% to 90%, non-condensing T > 40°C: < 90%, non-condensing	
<b>Mechanics</b>		<b>4PP320.1505-31</b>
Protection type	IP65 (front side) / IP20 (back side)	
Outer dimensions (W x H x D [mm])	435 x 330 x 71.5	
Weight	6.3 kg	

Required accessories		
0TB103.9	Plug 24 VDC screw clamp	▣ 1131
0TB103.91	Plug 24 VDC cage clamp	▣ 1131
	CompactFlash cards	▣ 1126

# Power Panel PP351 embedded 5.7" LCD monochrome



<b>Controller</b>	<b>4PP351.0571-01</b>
Processor	Geode LX800 500 MHz, MMX compatible
Main memory	128 MB DRAM
Graphics memory	8 MB shared memory (allocated from main memory)
CompactFlash slot	1 slot for Type I CompactFlash card
Mode/node switches	2, 16 digits each
<b>Display</b>	<b>4PP351.0571-01</b>
Type	LCD monochrome
Colors	8 shades of grey <sup>1)</sup>
Resolution	QVGA, 320 x 240 pixels
Diagonal	5.7"
Brightness	220 cd/m <sup>2</sup>
Half-brightness time	50,000 h
Touch screen	-
<b>Keys</b>	<b>4PP351.0571-01</b>
Function keys	16, with LED
Soft keys	6, with LED
System keys	Number block Cursor keys
<b>Interfaces</b>	<b>4PP351.0571-01</b>
Serial	
Type	RS232
Design	9-pin DSUB plug
Electrical isolation	No
Max. baud rate	115 kBits/s
USB	2x USB 2.0, connection type A <sup>1)</sup>
Ethernet	RJ45 twisted pair (10 BaseT / 100 BaseT)
<b>24 VDC supply</b>	<b>4PP351.0571-01</b>
Input voltage	24 VDC ±25%, electrically isolated
<b>Environmental conditions</b>	<b>4PP351.0571-01</b>
Temperature	
Operation	0 to +50°C
Storage	-20°C to +60°C
Relative humidity	
Operation	5% to 85%, non-condensing
Storage	T ≤ 40°C: 5% to 90%, non-condensing T > 40°C: < 90%, non-condensing
<b>Mechanics</b>	<b>4PP351.0571-01</b>
Protection type	IP65 (front side) / IP20 (back side)
Outer dimensions (W x H x D [mm])	212 x 245 x 55.5
Weight	1.4 kg

1) Automation Runtime limitation - max. 256 shades of grey, USB 1.1

Required accessories		
	Plug 24 VDC	1131
5AC900.057X-00	Legend strips for 5.7" panel, 1 sheet for labeling 3 panels. For Power Panel 4PPx51.0571-xx.	868
	CompactFlash cards	1126

1) Replacement part

# Power Panel PP351 embedded 5.7" TFT color



<b>Controller</b>		<b>4PP351.0571-35</b>
Processor	Geode LX800 500 MHz, MMX compatible	
Main memory	128 MB DRAM	
Graphics memory	8 MB shared memory (allocated from main memory)	
CompactFlash slot	1 slot for Type I CompactFlash card	
Mode/node switches	2, 16 digits each	
<b>Display</b>		<b>4PP351.0571-35</b>
Type	TFT color	
Colors	262.144 <sup>1)</sup>	
Resolution	QVGA, 320 x 240 pixels	
Diagonal	5.7"	
Brightness	500 cd/m <sup>2</sup>	
Half-brightness time	50,000 h	
Touch screen	-	
<b>Keys</b>		<b>4PP351.0571-35</b>
Function keys	16, with LED	
Soft keys	6, with LED	
System keys	Number block	
	Cursor keys	
<b>Interfaces</b>		<b>4PP351.0571-35</b>
Serial		
Type	RS232	
Design	9-pin DSUB plug	
Electrical isolation	No	
Max. baud rate	115 kBits/s	
USB	2x USB 2.0, connection type A <sup>1)</sup>	
Ethernet	RJ45 twisted pair (10 BaseT / 100 BaseT)	
<b>24 VDC supply</b>		<b>4PP351.0571-35</b>
Input voltage	24 VDC ±25%, electrically isolated	
<b>Environmental conditions</b>		<b>4PP351.0571-35</b>
Temperature		
Operation	0 to +50°C	
Storage	-20°C to +60°C	
Relative humidity		
Operation	5% to 85%, non-condensing	
Storage	T ≤ 40°C: 5% to 90%, non-condensing T > 40°C: < 90%, non-condensing	
<b>Mechanics</b>		<b>4PP351.0571-35</b>
Protection type	IP65 (front side) / IP20 (back side)	
Outer dimensions (W x H x D [mm])	212 x 245 x 55.5	
Weight	1.4 kg	

1) Automation Runtime limitation - max. 256 colors, USB 1.1

Required accessories		
	Plug 24 VDC	▣ 1131
5AC900.057X-00	Legend strips for 5.7" panel, 1 sheet for labeling 3 panels. For Power Panel 4PPx51.0571-xx.	▣ 868
	CompactFlash cards	▣ 1126

1) Replacement part

# Power Panel PP352 embedded 5.7" LCD color



<b>Controller</b>	<b>4PP352.0571-35</b>
Processor	Geode LX800 500 MHz, MMX compatible
Main memory	128 MB DRAM
Graphics memory	8 MB shared memory (allocated from main memory)
CompactFlash slot	1 slot for Type I CompactFlash card
Mode/node switches	2, 16 digits each
<b>Display</b>	<b>4PP352.0571-35</b>
Type	TFT color
Colors	262.144 <sup>1)</sup>
Resolution	QVGA, 320 x 240 pixels
Diagonal	5.7"
Brightness	500 cd/m <sup>2</sup>
Half-brightness time	50,000 h
Touch screen	-
<b>Keys</b>	<b>4PP352.0571-35</b>
Function keys	16, with LED
Soft keys	6, with LED
System keys	Number block Cursor keys
<b>Interfaces</b>	<b>4PP352.0571-35</b>
Serial	
Type	RS232
Design	9-pin DSUB plug
Electrical isolation	No
Max. baud rate	115 kBits/s
USB	2x USB 2.0, connection type A <sup>1)</sup>
Ethernet	RJ45 twisted pair (10 BaseT / 100 BaseT)
<b>24 VDC supply</b>	<b>4PP352.0571-35</b>
Input voltage	24 VDC ±25%, electrically isolated
<b>Environmental conditions</b>	<b>4PP352.0571-35</b>
Temperature	
Operation	0 to +50°C
Storage	-20°C to +60°C
Relative humidity	
Operation	5% to 85%, non-condensing
Storage	T ≤ 40°C: 5% to 90%, non-condensing T > 40°C: < 90%, non-condensing
<b>Mechanics</b>	<b>4PP352.0571-35</b>
Protection type	IP65 (front side) / IP20 (back side)
Outer dimensions (W x H x D [mm])	212 x 245 x 55.5
Weight	1.4 kg

1) Automation Runtime limitation - max. 256 colors, USB 1.1

Required accessories		
	Plug 24 VDC	1131
5AC900.057X-00	Legend strips for 5.7" panel, 1 sheet for labeling 3 panels. For Power Panel 4PPx51.0571-xx.	868
	CompactFlash cards	1126

1) Replacement part

# Power Panel PP381 embedded 10.4" TFT color touch screen



<b>Controller</b>	<b>4PP381.1043-31</b>
Processor	Geode LX800 500 MHz, MMX compatible
Main memory	128 MB DRAM
Graphics memory	8 MB shared memory (allocated from main memory)
CompactFlash slot	1 slot for Type I CompactFlash card
Mode/node switches	2, 16 digits each
<b>Display</b>	<b>4PP381.1043-31</b>
Type	TFT color
Colors	262.144 <sup>1)</sup>
Resolution	VGA, 640 x 480 pixels
Diagonal	10.4"
Brightness	450 cd/m <sup>2</sup>
Half-brightness time	55,000 h
Touch screen	Analog resistive
<b>Keys</b>	<b>4PP381.1043-31</b>
Function keys	28, with LED
Soft keys	10, with LED
System keys	Number block, cursor keys
<b>Interfaces</b>	<b>4PP381.1043-31</b>
Serial	
Type	RS232
Design	9-pin DSUB plug
Electrical isolation	No
Max. baud rate	115 kBits/s
USB	2x USB 2.0, connection type A <sup>1)</sup>
Ethernet	RJ45 twisted pair (10 BaseT / 100 BaseT)
<b>24 VDC supply</b>	<b>4PP381.1043-31</b>
Input voltage	24 VDC ±25%, electrically isolated
<b>Environmental conditions</b>	<b>4PP381.1043-31</b>
Temperature	
Operation	0 to +50°C
Storage	-20°C to +70°C
Relative humidity	
Operation	5% to 85%, non-condensing
Storage	T ≤ 40°C: 5% to 90%, non-condensing T > 40°C: < 90%, non-condensing
<b>Mechanics</b>	<b>4PP381.1043-31</b>
Protection type	IP65 (front side) / IP20 (back side)
Outer dimensions (W x H x D [mm])	323 x 358 x 65.5
Weight	4.6 kg

1) Automation Runtime limitation - max. 256 colors, USB 1.1

Required accessories		
	Plug 24 VDC	1131
5AC900.104X-00	Legend strips for 10.4" panel, 1 sheet for labeling 1 panel. For Power Panel 4PPx51.1043-xx and 4PPx81.1043-xx devices.	868
	CompactFlash cards	1126

1) Replacement part

# Power Panel PP420 embedded 5.7" LCD monochrome touch screen



	4PP420.0571-45	4PP420.0571-85
<b>Controller</b>	<b>4PP420.0571-45</b>	<b>4PP420.0571-85</b>
Processor	Geode LX800 500 MHz, MMX compatible	Geode LX800 500 MHz, MMX compatible
Main memory	128 MB DRAM	128 MB DRAM
Graphics memory	8 MB shared memory (allocated from main memory)	8 MB shared memory (allocated from main memory)
SRAM	512 KB, battery-buffered	512 KB, battery-buffered
CompactFlash slot	1 slot for Type I CompactFlash card	1 slot for Type I CompactFlash card
aPCI slots	1	2
Watchdog	MTCX	MTCX
Power failure logic	MTCX 10 ms buffer time	MTCX 10 ms buffer time
Battery	Lithium, 950 mAh, exchanged from the outside	Lithium, 950 mAh, exchanged from the outside
Real-time clock	Battery-buffered	Battery-buffered
Mode/node switches	2, 16 digits each	2, 16 digits each
<b>Display</b>	<b>4PP420.0571-45</b>	<b>4PP420.0571-85</b>
Type	LCD monochrome	LCD monochrome
Colors	8 shades of grey <sup>1)</sup>	8 shades of grey <sup>1)</sup>
Resolution	QVGA, 320 x 240 pixels	QVGA, 320 x 240 pixels
Diagonal	5.7"	5.7"
Brightness	220 cd/m <sup>2</sup>	220 cd/m <sup>2</sup>
Half-brightness time	50,000 h	50,000 h
Touch screen	Analog resistive	Analog resistive
1) Automation Runtime limitation - max. 256 shades of grey, USB 1.1		
<b>Interfaces</b>	<b>4PP420.0571-45</b>	<b>4PP420.0571-85</b>
<b>Serial</b>		
Type	RS232	RS232
Design	9-pin DSUB plug	9-pin DSUB plug
Electrical isolation	No	No
Max. baud rate	115 kBits/s	115 kBits/s
<b>USB</b>	2x USB 2.0, connection type A <sup>1)</sup>	2x USB 2.0, connection type A <sup>1)</sup>
<b>Ethernet</b>	RJ45 twisted pair (10 BaseT / 100 BaseT)	RJ45 twisted pair (10 BaseT / 100 BaseT)
1) Automation Runtime limitation - max. 256 shades of grey, USB 1.1		
<b>24 VDC supply</b>	<b>4PP420.0571-45</b>	<b>4PP420.0571-85</b>
Input voltage	24 VDC ±25%, electrically isolated	24 VDC ±25%, electrically isolated
<b>Environmental conditions</b>	<b>4PP420.0571-45</b>	<b>4PP420.0571-85</b>
<b>Temperature</b>		
Operation	0 to +50°C	0 to +50°C
Storage	-20°C to +60°C	-20°C to +60°C
<b>Relative humidity</b>		
Operation	5% to 85%, non-condensing	5% to 85%, non-condensing
Storage	T <= 40°C: 5% to 90%, non-condensing T > 40°C: < 90%, non-condensing	T <= 40°C: 5% to 90%, non-condensing T > 40°C: < 90%, non-condensing
<b>Mechanics</b>	<b>4PP420.0571-45</b>	<b>4PP420.0571-85</b>
Protection type	IP65 (front side) / IP20 (back side)	IP65 (front side) / IP20 (back side)
Outer dimensions (W x H x D [mm])	212 x 156 x 76	212 x 156 x 76
Weight	1.7 kg (without aPCI module)	1.7 kg (without aPCI module)

Required accessories		
	Network and fieldbus modules	▣ 611
	Lithium battery, 3 V / 950 mAh, button cell <sup>1)</sup>	▣ 1128
0TB103.9	Plug 24 VDC screw clamp	▣ 1131
0TB103.91	Plug 24 VDC cage clamp	▣ 1131
	CompactFlash cards	▣ 1126

1) Replacement part





# Power Panel PP420 embedded 5.7" TFT color touch screen



Controller	4PP420.0571-75	4PP420.0571-B5
Processor	Geode LX800 500 MHz, MMX compatible	Geode LX800 500 MHz, MMX compatible
Main memory	128 MB DRAM	128 MB DRAM
Graphics memory	8 MB shared memory (allocated from main memory)	8 MB shared memory (allocated from main memory)
SRAM	512 KB, battery-buffered	256 KB, battery-buffered
CompactFlash slot	1 slot for Type I CompactFlash card	1 slot for Type I CompactFlash card
aPCI slots	1	2
Watchdog	MTCX	MTCX
Power failure logic	MTCX 10 ms buffer time	MTCX 10 ms buffer time
Battery	Lithium, 950 mAh, exchanged from the outside	Lithium, 950 mAh, exchanged from the outside
Real-time clock	Battery-buffered	Battery-buffered
Mode/node switches	2, 16 digits each	2, 16 digits each
Display	4PP420.0571-75	4PP420.0571-B5
Type	TFT color	TFT color
Colors	262.144 <sup>1)</sup>	262.144 <sup>1)</sup>
Resolution	QVGA, 320 x 240 pixels	QVGA, 320 x 240 pixels
Diagonal	5.7"	5.7"
Brightness	500 cd/m <sup>2</sup>	500 cd/m <sup>2</sup>
Half-brightness time	50,000 h	50,000 h
Touch screen	Analog resistive	Analog resistive
1) Automation Runtime limitation - max. 256 colors, USB 1.1		
Interfaces	4PP420.0571-75	4PP420.0571-B5
Serial		
Type	RS232	RS232
Design	9-pin DSUB plug	9-pin DSUB plug
Electrical isolation	No	No
Max. baud rate	115 kBits/s	115 kBits/s
USB	2x USB 2.0, connection type A <sup>1)</sup>	2x USB 2.0, connection type A <sup>1)</sup>
Ethernet	RJ45 twisted pair (10 BaseT / 100 BaseT)	RJ45 twisted pair (10 BaseT / 100 BaseT)
1) Automation Runtime limitation - max. 256 colors, USB 1.1		
24 VDC supply	4PP420.0571-75	4PP420.0571-B5
Input voltage	24 VDC ±25%, electrically isolated	24 VDC ±25%, electrically isolated
Environmental conditions	4PP420.0571-75	44PP420.0571-B5
Temperature		
Operation	0 to +50°C	0 to +50°C
Storage	-20°C to +60°C	-20°C to +60°C
Relative humidity		
Operation	5% to 85%, non-condensing	5% to 85%, non-condensing
Storage	T ≤ 40°C: 5% to 90%, non-condensing T > 40°C: < 90%, non-condensing	T ≤ 40°C: 5% to 90%, non-condensing T > 40°C: < 90%, non-condensing
Mechanics	4PP420.0571-75	4PP420.0571-B5
Protection type	IP65 (front side) / IP20 (back side)	IP65 (front side) / IP20 (back side)
Outer dimensions (W x H x D [mm])	212 x 156 x 76	212 x 156 x 98
Weight	1.7 kg (without aPCI module)	2.0 kg (without aPCI module)

Required accessories		
	Network and fieldbus modules	▣ 611
	Lithium battery, 3 V / 950 mAh, button cell <sup>1)</sup>	▣ 1128
0TB103.9	Plug 24 VDC screw clamp	▣ 1131
0TB103.91	Plug 24 VDC cage clamp	▣ 1131
	CompactFlash cards	▣ 1126

1) Replacement part



<b>Controller</b>		<b>4PP420.0573-75</b>
Processor	Geode LX800 500 MHz, MMX compatible	
Main memory	128 MB DRAM	
Graphics memory	8 MB shared memory (allocated from main memory)	
SRAM	512 KB, battery-buffered	
CompactFlash slot	1 slot for Type I CompactFlash card	
aPCI slots	1	
Watchdog	MTCX	
Power failure logic	MTCX 10 ms buffer time	
Battery	Lithium, 950 mAh, exchanged from the outside	
Real-time clock	Battery-buffered	
Mode/node switches	2, 16 digits each	
<b>Display</b>		<b>4PP420.0573-75</b>
Type	TFT color	
Colors	262.144 <sup>1)</sup>	
Resolution	VGA, 640 x 480 pixels	
Diagonal	5.7"	
Brightness	350 cd/m <sup>2</sup>	
Half-brightness time	75,000 h	
Touch screen	Analog resistive	
1) Automation Runtime limitation - max. 256 colors, USB 1.1		
<b>Interfaces</b>		<b>4PP420.0573-75</b>
Serial		
Type	RS232	
Design	9-pin DSUB plug	
Electrical isolation	No	
Max. baud rate	115 kBits/s	
USB	2x USB 2.0, connection type A <sup>1)</sup>	
Ethernet	RJ45 twisted pair (10 BaseT / 100 BaseT)	
1) Automation Runtime limitation - max. 256 colors, USB 1.1		
<b>24 VDC supply</b>		<b>4PP420.0573-75</b>
Input voltage	24 VDC ±25%, electrically isolated	
<b>Environmental conditions</b>		<b>4PP420.0573-75</b>
Temperature		
Operation	0 to +50°C	
Storage	-20°C to +60°C	
Relative humidity		
Operation	5% to 85%, non-condensing	
Storage	T ≤ 40°C: 5% to 90%, non-condensing T > 40°C: < 90%, non-condensing	
<b>Mechanics</b>		<b>4PP420.0573-75</b>
Protection type	IP65 (front side) / IP20 (back side)	
Outer dimensions (W x H x D [mm])	212 x 156 x 76	
Weight	1.7 kg (without aPCI module)	

Required accessories		
	Network and fieldbus modules	▣ 611
	Lithium battery, 3 V / 950 mAh, button cell <sup>1)</sup>	▣ 1128
0TB103.9	Plug 24 VDC screw clamp	▣ 1131
0TB103.91	Plug 24 VDC cage clamp	▣ 1131
	CompactFlash cards	▣ 1126

1) Replacement part

# Power Panel PP420 embedded 10.4" TFT color touch screen



Controller	4PP420.1043-75	4PP420.1043-B5
Processor	Geode LX800 500 MHz, MMX compatible	Geode LX800 500 MHz, MMX compatible
Main memory	128 MB DRAM	128 MB DRAM
Graphics memory	8 MB shared memory (allocated from main memory)	8 MB shared memory (allocated from main memory)
SRAM	512 KB, battery-buffered	512 KB, battery-buffered
CompactFlash slot	1 slot for Type I CompactFlash card	1 slot for Type I CompactFlash card
aPCI slots	1	2
Watchdog	MTCX	MTCX
Power failure logic	MTCX 10 ms buffer time	MTCX 10 ms buffer time
Battery	Lithium, 950 mAh, exchanged from the outside	Lithium, 950 mAh, exchanged from the outside
Real-time clock	Battery-buffered	Battery-buffered
Mode/node switches	2, 16 digits each	2, 16 digits each
Display	4PP420.1043-75	4PP420.1043-B5
Type	TFT color	TFT color
Colors	262.144 <sup>1)</sup>	262.144 <sup>1)</sup>
Resolution	VGA, 640 x 480 pixels	VGA, 640 x 480 pixels
Diagonal	10.4"	10.4"
Brightness	450 cd/m <sup>2</sup>	450 cd/m <sup>2</sup>
Half-brightness time	55,000 h	55,000 h
Touch screen	Analog resistive	Analog resistive
1) Automation Runtime limitation - max. 256 colors, USB 1.1		
Interfaces	4PP420.1043-75	4PP420.1043-B5
Serial		
Type	RS232	RS232
Design	9-pin DSUB plug	9-pin DSUB plug
Electrical isolation	No	No
Max. baud rate	115 kBits/s	115 kBits/s
USB	2x USB 2.0, connection type A <sup>1)</sup>	2x USB 2.0, connection type A <sup>1)</sup>
Ethernet	RJ45 twisted pair (10 BaseT / 100 BaseT)	RJ45 twisted pair (10 BaseT / 100 BaseT)
1) Automation Runtime limitation - max. 256 colors, USB 1.1		
24 VDC supply	4PP420.1043-75	4PP420.1043-B5
Input voltage	24 VDC ±25%, electrically isolated	24 VDC ±25%, electrically isolated
Environmental conditions	4PP220.1043-75	4PP420.1043-B5
Temperature		
Operation	0 to +50°C	0 to +50°C
Storage	-20°C to +70°C	-20°C to +70°C
Relative humidity		
Operation	5% to 85%, non-condensing	5% to 85%, non-condensing
Storage	T ≤ 40°C: 5% to 90%, non-condensing T > 40°C: < 90%, non-condensing	T ≤ 40°C: 5% to 90%, non-condensing T > 40°C: < 90%, non-condensing
Mechanics	4PP220.1043-75	4PP420.1043-B5
Protection type	IP65 (front side) / IP20 (back side)	IP65 (front side) / IP20 (back side)
Outer dimensions (W x H x D [mm])	323 x 260 x 86	323 x 260 x 108
Weight	3.9 kg (without aPCI module)	4.2 kg (without aPCI module)

Required accessories		
	Network and fieldbus modules	▣ 611
	Lithium battery, 3 V / 950 mAh, button cell <sup>1)</sup>	▣ 1128
0TB103.9	Plug 24 VDC screw clamp	▣ 1131
0TB103.91	Plug 24 VDC cage clamp	▣ 1131
	CompactFlash cards	▣ 1126

1) Replacement part

# Power Panel PP420 embedded 15" TFT color touch screen



	4PP420.1505-75	4PP420.1505-B5
<b>Controller</b>	<b>4PP420.1505-75</b>	<b>4PP420.1505-B5</b>
Processor	Geode LX800 500 MHz, MMX compatible	Geode LX800 500 MHz, MMX compatible
Main memory	128 MB DRAM	128 MB DRAM
Graphics memory	8 MB shared memory (allocated from main memory)	8 MB shared memory (allocated from main memory)
SRAM	512 KB, battery-buffered	512 KB, battery-buffered
CompactFlash slot	1 slot for Type I CompactFlash card	1 slot for Type I CompactFlash card
aPCI slots	1	2
Watchdog	MTCX	MTCX
Power failure logic	MTCX 10 ms buffer time	MTCX 10 ms buffer time
Battery	Lithium, 950 mAh, exchanged from the outside	Lithium, 950 mAh, exchanged from the outside
Real-time clock	Battery-buffered	Battery-buffered
Mode/node switches	2, 16 digits each	2, 16 digits each
<b>Display</b>	<b>4PP420.1505-75</b>	<b>4PP420.1505-B5</b>
Type	TFT color	TFT color
Colors	262.144 <sup>1)</sup>	262.144 <sup>1)</sup>
Resolution	XGA, 1024 x 768 pixels	XGA, 1024 x 768 pixels
Diagonal	15"	15"
Brightness	250 cd/m <sup>2</sup>	250 cd/m <sup>2</sup>
Half-brightness time	50,000 h	50,000 h
Touch screen	Analog resistive	Analog resistive
1) Automation Runtime limitation - max. 256 colors, USB 1.1		
<b>Interfaces</b>	<b>4PP420.1505-75</b>	<b>4PP420.1505-B5</b>
<b>Serial</b>		
Type	RS232	RS232
Design	9-pin DSUB plug	9-pin DSUB plug
Electrical isolation	No	No
Max. baud rate	115 kBits/s	115 kBits/s
<b>USB</b>	2x USB 2.0, connection type A <sup>1)</sup>	2x USB 2.0, connection type A <sup>1)</sup>
<b>Ethernet</b>	RJ45 twisted pair (10 BaseT / 100 BaseT)	RJ45 twisted pair (10 BaseT / 100 BaseT)
1) Automation Runtime limitation - max. 256 colors, USB 1.1		
<b>24 VDC supply</b>	<b>4PP420.1505-75</b>	<b>4PP420.1505-B5</b>
Input voltage	24 VDC ±25%, electrically isolated	24 VDC ±25%, electrically isolated
<b>Environmental conditions</b>	<b>4PP420.1505-75</b>	<b>4PP420.1505-B5</b>
<b>Temperature</b>		
Operation	0°C to +50°C	0°C to +50°C
Storage	-20°C to +60°C	-20°C to +60°C
<b>Relative humidity</b>		
Operation	5% to 85%, non-condensing	5% to 85%, non-condensing
Storage	T ≤ 40°C: 5% to 90%, non-condensing T > 40°C: < 90%, non-condensing	T ≤ 40°C: 5% to 90%, non-condensing T > 40°C: < 90%, non-condensing
<b>Mechanics</b>	<b>4PP420.1505-75</b>	<b>4PP420.1505-B5</b>
Protection type	IP65 (front side) / IP20 (back side)	IP65 (front side) / IP20 (back side)
Outer dimensions (W x H x D [mm])	435 x 330 x 87	435 x 330 x 109
Weight	6.5 kg	6.8 kg

Required accessories		
	Network and fieldbus modules	▣ 611
	Lithium battery, 3 V / 950 mAh, button cell <sup>1)</sup>	▣ 1128
0TB103.9	Plug 24 V screw clamp	▣ 1131
0TB103.91	Plug 24 VDC cage clamp	▣ 1131
	CompactFlash cards	▣ 1126

1) Replacement part

# Power Panel PP451 embedded 5.7" LCD monochrome



	4PP451.0571-45	4PP451.0571-85
<b>Controller</b>	<b>4PP451.0571-45</b>	<b>4PP451.0571-85</b>
Processor	Geode LX800 500 MHz, MMX compatible	Geode LX800 500 MHz, MMX compatible
Main memory	128 MB DRAM	128 MB DRAM
Graphics memory	8 MB shared memory (allocated from main memory)	8 MB shared memory (allocated from main memory)
SRAM	512 KB, battery-buffered	512 KB, battery-buffered
CompactFlash slot	1 slot for Type I CompactFlash card	1 slot for Type I CompactFlash card
aPCI slots	1	2
Watchdog	MTCX	MTCX
Power failure logic	MTCX 10 ms buffer time	MTCX 10 ms buffer time
Battery	Lithium, 950 mAh, exchanged from the outside	Lithium, 950 mAh, exchanged from the outside
Real-time clock	Battery-buffered	Battery-buffered
Mode/node switches	2, 16 digits each	2, 16 digits each
<b>Display</b>	<b>4PP451.0571-45</b>	<b>4PP451.0571-85</b>
Type	LCD monochrome	LCD monochrome
Colors	8 shades of grey <sup>1)</sup>	8 shades of grey <sup>1)</sup>
Resolution	QVGA, 320 x 240 pixels	QVGA, 320 x 240 pixels
Diagonal	5.7"	5.7"
Brightness	220 cd/m <sup>2</sup>	220 cd/m <sup>2</sup>
Half-brightness time	50,000 h	50,000 h
Touch screen	-	-
<b>Keys</b>	<b>4PP451.0571-45</b>	<b>4PP451.0571-85</b>
Function keys	16, with LED	16, with LED
Soft keys	6, with LED	6, with LED
System keys	Number block Cursor keys	Number block Cursor keys
<b>Interfaces</b>	<b>4PP451.0571-45</b>	<b>4PP451.0571-85</b>
<b>Serial</b>		
Type	RS232	RS232
Design	9-pin DSUB plug	9-pin DSUB plug
Electrical isolation	No	No
Max. baud rate	115 kBits/s	115 kBits/s
<b>USB</b>		
	2x USB 2.0, connection type A <sup>1)</sup>	2x USB 2.0, connection type A <sup>1)</sup>
<b>Ethernet</b>		
	RJ45 twisted pair (10 BaseT / 100 BaseT)	RJ45 twisted pair (10 BaseT / 100 BaseT)
<b>24 VDC supply</b>	<b>4PP451.0571-45</b>	<b>4PP451.0571-85</b>
Input voltage	24 VDC ±25%, electrically isolated	24 VDC ±25%, electrically isolated
<b>Environmental conditions</b>	<b>4PP451.0571-45</b>	<b>4PP451.0571-85</b>
<b>Temperature</b>		
Operation	0 to +50°C	0 to +50°C
Storage	-20°C to +60°C	-20°C to +60°C
<b>Relative humidity</b>		
Operation	5% to 85%, non-condensing	5% to 85%, non-condensing
Storage	T ≤ 40°C: 5% to 90%, non-condensing T > 40°C: < 90%, non-condensing	T ≤ 40°C: 5% to 90%, non-condensing T > 40°C: < 90%, non-condensing
<b>Mechanics</b>	<b>4PP451.0571-75</b>	<b>4PP451.0571-B5</b>
Protection type	IP65 (front side) / IP20 (back side)	IP65 (front side) / IP20 (back side)
Outer dimensions (W x H x D [mm])	212 x 245 x 76.5	212 x 245 x 98.5
Weight	2.4 kg	2.7 kg
1) Automation Runtime limitation - max. 256 shades of grey, USB 1.1		
<b>Required accessories</b>		
	Network and fieldbus modules	▣ 611
	Lithium battery, 3 V / 950 mAh, button cell <sup>1)</sup>	▣ 1128
	Plug 24 VDC	▣ 1131
5AC900.057X-00	Legend strips for 5.7" panel, 1 sheet for labeling 3 panels. For Power Panel 4PPx51.0571-xx.	▣ 868
	CompactFlash cards	▣ 1128

1) Replacement part

# Power Panel PP451 embedded 5.7" TFT color



	4PP451.0571-75	4PP451.0571-B5
<b>Controller</b>	<b>4PP451.0571-75</b>	<b>4PP451.0571-B5</b>
Processor	Geode LX800 500 MHz, MMX compatible	Geode LX800 500 MHz, MMX compatible
Main memory	128 MB DRAM	128 MB DRAM
Graphics memory	8 MB shared memory (allocated from main memory)	8 MB shared memory (allocated from main memory)
SRAM	512 KB, battery-buffered	512 KB, battery-buffered
CompactFlash slot	1 slot for Type I CompactFlash card	1 slot for Type I CompactFlash card
aPCI slots	1	2
Watchdog	MTCX	MTCX
Power failure logic	MTCX 10 ms buffer time	MTCX 10 ms buffer time
Battery	Lithium, 950 mAh, exchanged from the outside	Lithium, 950 mAh, exchanged from the outside
Real-time clock	Battery-buffered	Battery-buffered
Mode/node switches	2, 16 digits each	2, 16 digits each
<b>Display</b>	<b>4PP451.0571-75</b>	<b>4PP451.0571-B5</b>
Type	TFT color	TFT color
Colors	262,144 <sup>1)</sup>	262,144 <sup>1)</sup>
Resolution	QVGA, 320 x 240 pixels	QVGA, 320 x 240 pixels
Diagonal	5.7"	5.7"
Brightness	500 cd/m <sup>2</sup>	500 cd/m <sup>2</sup>
Half-brightness time	50,000 h	50,000 h
Touch screen	-	-
<b>Keys</b>	<b>4PP451.0571-75</b>	<b>4PP451.0571-B5</b>
Function keys	16, with LED	16, with LED
Soft keys	6, with LED	6, with LED
System keys	Number block Cursor keys	Number block Cursor keys
<b>Interfaces</b>	<b>4PP451.0571-75</b>	<b>4PP451.0571-B5</b>
Serial		
Type	RS232	RS232
Design	9-pin DSUB plug	9-pin DSUB plug
Electrical isolation	No	No
Max. baud rate	115 kBits/s	115 kBits/s
USB	2x USB 2.0, connection type A <sup>1)</sup>	2x USB 2.0, connection type A <sup>1)</sup>
Ethernet	RJ45 twisted pair (10 BaseT / 100 BaseT)	RJ45 twisted pair (10 BaseT / 100 BaseT)
<b>24 VDC supply</b>	<b>4PP451.0571-75</b>	<b>4PP451.0571-B5</b>
Input voltage	24 VDC ±25%, electrically isolated	24 VDC ±25%, electrically isolated
<b>Environmental conditions</b>	<b>4PP451.0571-75</b>	<b>4PP451.0571-B5</b>
Temperature		
Operation	0 to +50°C	0 to +50°C
Storage	-20°C to +60°C	-20°C to +60°C
Relative humidity		
Operation	5% to 85%, non-condensing	5% to 85%, non-condensing
Storage	T ≤ 40°C: 5% to 90%, non-condensing T > 40°C: < 90%, non-condensing	T ≤ 40°C: 5% to 90%, non-condensing T > 40°C: < 90%, non-condensing
<b>Mechanics</b>	<b>4PP451.0571-75</b>	<b>4PP451.0571-B5</b>
Protection type	IP65 (front side) / IP20 (back side)	IP65 (front side) / IP20 (back side)
Outer dimensions (W x H x D [mm])	212 x 245 x 76.5	212 x 245 x 98.5
Weight	2.4 kg	2.7 kg
1) Automation Runtime limitation - max. 256 colors, USB 1.1		
<b>Required accessories</b>		
	Network and fieldbus modules	▣ 611
	Lithium battery, 3 V / 950 mAh, button cell <sup>1)</sup>	▣ 1128
	Plug 24 VDC	▣ 1131
5AC900.057X-00	Legend strips for 5.7" panel, 1 sheet for labeling 3 panels. For Power Panel 4PPx51.0571-xx.	▣ 868
	CompactFlash cards	▣ 1126

1) Replacement part

# Power Panel PP452 embedded 5.7" LCD monochrome



<b>Controller</b>	<b>4PP452.0571-45</b>
Processor	Geode LX800 500 MHz, MMX compatible
Main memory	128 MB DRAM
Graphics memory	8 MB shared memory (allocated from main memory)
SRAM	512 KB, battery-buffered
CompactFlash slot	1 slot for Type I CompactFlash card
aPCI slots	1
Watchdog	MTCX
Power failure logic	MTCX 10 ms buffer time
Battery	Lithium, 950 mAh, exchanged from the outside
Real-time clock	Battery-buffered
Mode/node switches	2, 16 digits each
<b>Display</b>	<b>4PP452.0571-45</b>
Type	LCD monochrome
Colors	8 shades of grey <sup>1)</sup>
Resolution	QVGA, 320 x 240 pixels
Diagonal	5.7"
Brightness	220 cd/m <sup>2</sup>
Half-brightness time	50,000 h
Touch screen	-
<b>Keys</b>	<b>4PP452.0571-45</b>
Function keys	16, with LED
Soft keys	6, with LED
System keys	Number block Cursor keys
<b>Interfaces</b>	<b>4PP452.0571-45</b>
Serial	
Type	RS232
Design	9-pin DSUB plug
Electrical isolation	No
Max. baud rate	115 kBits/s
USB	2x USB 2.0, connection type A <sup>1)</sup>
Ethernet	RJ45 twisted pair (10 BaseT / 100 BaseT)
<b>24 VDC supply</b>	<b>4PP452.0571-45</b>
Input voltage	24 VDC ±25%, electrically isolated
<b>Environmental conditions</b>	<b>4PP452.0571-45</b>
Temperature	
Operation	0 to +50°C
Storage	-20°C to +60°C
Relative humidity	
Operation	5% to 85%, non-condensing
Storage	T ≤ 40°C: 5% to 90%, non-condensing T > 40°C: < 90%, non-condensing
<b>Mechanics</b>	<b>4PP452.0571-45</b>
Protection type	IP65 (front side) / IP20 (back side)
Outer dimensions (W x H x D [mm])	302 x 187 x 76
Weight	2.4 kg
<small>1) Automation Runtime limitation - max. 256 shades of grey, USB 1.1</small>	
<b>Required accessories</b>	
Network and fieldbus modules	▣ 611
Lithium battery, 3 V / 950 mAh, button cell <sup>1)</sup>	▣ 1128
Plug 24 VDC	▣ 1131
5AC900.057X-00 Legend strips for 5.7" panel, 1 sheet for labeling 3 panels. For Power Panel 4PPx51.0571-xx.	▣ 868
CompactFlash cards	▣ 1126

1) Replacement part



# Power Panel PP452 embedded 5.7" TFT color



	4PP452.0571-75	4PP452.0571-B5
<b>Controller</b>	<b>4PP452.0571-75</b>	<b>4PP452.0571-B5</b>
Processor	Geode LX800 500 MHz, MMX compatible	Geode LX800 500 MHz, MMX compatible
Main memory	128 MB DRAM	128 MB DRAM
Graphics memory	8 MB shared memory (allocated from main memory)	8 MB shared memory (allocated from main memory)
SRAM	512 KB, battery-buffered	512 KB, battery-buffered
CompactFlash slot	1 slot for Type I CompactFlash card	1 slot for Type I CompactFlash card
aPCI slots	1	2
Watchdog	MTCX	MTCX
Power failure logic	MTCX 10 ms buffer time	MTCX 10 ms buffer time
Battery	Lithium, 950 mAh, exchanged from the outside	Lithium, 950 mAh, exchanged from the outside
Real-time clock	Battery-buffered	Battery-buffered
Mode/node switches	2, 16 digits each	2, 16 digits each
<b>Display</b>	<b>4PP452.0571-75</b>	<b>4PP452.0571-B5</b>
Type	TFT color	TFT color
Colors	262,144 <sup>1)</sup>	262,144 <sup>1)</sup>
Resolution	QVGA, 320 x 240 pixels	QVGA, 320 x 240 pixels
Diagonal	5.7"	5.7"
Brightness	500 cd/m <sup>2</sup>	500 cd/m <sup>2</sup>
Half-brightness time	50,000 h	50,000 h
Touch screen	-	-
<b>Keys</b>	<b>4PP452.0571-75</b>	<b>4PP452.0571-B5</b>
Function keys	16, with LED	16, with LED
Soft keys	6, with LED	6, with LED
System keys	Number block Cursor keys	Number block Cursor keys
<b>Interfaces</b>	<b>4PP452.0571-75</b>	<b>4PP452.0571-B5</b>
Serial		
Type	RS232	RS232
Design	9-pin DSUB plug	9-pin DSUB plug
Electrical isolation	No	No
Max. baud rate	115 kBits/s	115 kBits/s
USB	2x USB 2.0, connection type A <sup>1)</sup>	2x USB 2.0, connection type A <sup>1)</sup>
Ethernet	RJ45 twisted pair (10 BaseT / 100 BaseT)	RJ45 twisted pair (10 BaseT / 100 BaseT)
<b>24 VDC supply</b>	<b>4PP452.0571-75</b>	<b>4PP452.0571-B5</b>
Input voltage	24 VDC ±25%, electrically isolated	24 VDC ±25%, electrically isolated
<b>Environmental conditions</b>	<b>4PP452.0571-75</b>	<b>4PP452.0571-B5</b>
Temperature		
Operation	0 to +50°C	0 to +50°C
Storage	-20°C to +60°C	-20°C to +60°C
Relative humidity		
Operation	5% to 85%, non-condensing	5% to 85%, non-condensing
Storage	T ≤ 40°C: 5% to 90%, non-condensing T > 40°C: < 90%, non-condensing	T ≤ 40°C: 5% to 90%, non-condensing T > 40°C: < 90%, non-condensing
<b>Mechanics</b>	<b>4PP452.0571-75</b>	<b>4PP452.0571-B5</b>
Protection type	IP65 (front side) / IP20 (back side)	IP65 (front side) / IP20 (back side)
Outer dimensions (W x H x D [mm])	302 x 187 x 76	302 x 187 x 98
Weight	2.4 kg	2.7 kg
1) Automation Runtime limitation - max. 256 colors, USB 1.1		
<b>Required accessories</b>		
	Network and fieldbus modules	▣ 611
	Lithium battery, 3 V / 950 mAh, button cell <sup>1)</sup>	▣ 1128
	Plug 24 VDC	▣ 1131
5AC900.057X-00	Legend strips for 5.7" panel, 1 sheet for labeling 3 panels. For Power Panel 4PPx51.0571-xx.	▣ 868
	CompactFlash cards	▣ 1126

1) Replacement part

# Power Panel PP480 embedded 10.4" TFT color touch screen



<b>Controller</b>	<b>4PP480.1043-75</b>
Processor	Geode LX800 500 MHz, MMX compatible
Main memory	128 MB DRAM
Graphics memory	8 MB shared memory (allocated from main memory)
SRAM	512 KB, battery-buffered
CompactFlash slot	1 slot for Type I CompactFlash card
aPCI slots	1
Watchdog	MTCX
Power failure logic	MTCX 10 ms buffer time
Battery	Lithium, 950 mAh, exchanged from the outside
Real-time clock	Battery-buffered
Mode/node switches	2, 16 digits each
<b>Display</b>	<b>4PP480.1043-75</b>
Type	TFT color
Colors	262.144 <sup>1)</sup>
Resolution	VGA, 640 x 480 pixels
Diagonal	10.4"
Brightness	450 cd/m <sup>2</sup>
Half-brightness time	55,000 h
Touch screen	Analog resistive
<b>Keys</b>	<b>4PP480.1043-75</b>
Function keys	12, with LED
Soft keys	10, with LED
<b>Interfaces</b>	<b>4PP480.1043-75</b>
Serial	
Type	RS232
Design	9-pin DSUB plug
Electrical isolation	No
Max. baud rate	115 kBits/s
USB	2x USB 2.0, connection type A <sup>1)</sup>
Ethernet	RJ45 twisted pair (10 BaseT / 100 BaseT)
<b>24 VDC supply</b>	<b>4PP480.1043-75</b>
Input voltage	24 VDC ±25%, electrically isolated
<b>Environmental conditions</b>	<b>4PP480.1043-75</b>
Temperature	
Operation	0 to +50°C
Storage	-20°C to +70°C
Relative humidity	
Operation	5% to 85%, non-condensing
Storage	T ≤ 40°C: 5% to 90%, non-condensing T > 40°C: < 90%, non-condensing
<b>Mechanics</b>	<b>4PP480.1043-75</b>
Protection type	IP65 (front side) / IP20 (back side)
Outer dimensions (W x H x D [mm])	323 x 260 x 86
Weight	3.9 kg

1) Automation Runtime limitation - max. 256 colors, USB 1.1

Required accessories		
	Network and fieldbus modules	611
	Lithium battery, 3 V / 950 mAh, button cell <sup>1)</sup>	1128
	Plug 24 VDC	1131
5AC900.104X-02	Legend strips for 10.4" panel, 1 sheet for labeling 3 panels. For Power Panel 4PPx80.1043-xx.	868
	CompactFlash cards	1126

1) Replacement part

# Power Panel PP480 embedded 15" TFT color touch screen



	4PP480.1505-75	4PP480.1505-B5
<b>Controller</b>	<b>4PP480.1505-75</b>	<b>4PP480.1505-B5</b>
Processor	Geode LX800 500 MHz, MMX compatible	Geode LX800 500 MHz, MMX compatible
Main memory	128 MB DRAM	128 MB DRAM
Graphics memory	8 MB shared memory (allocated from main memory)	8 MB shared memory (allocated from main memory)
SRAM	512 KB, battery-buffered	512 KB, battery-buffered
CompactFlash slot	1 slot for Type I CompactFlash card	1 slot for Type I CompactFlash card
aPCI slots	1	2
Watchdog	MTCX	MTCX
Power failure logic	MTCX 10 ms buffer time	MTCX 10 ms buffer time
Battery	Lithium, 950 mAh, exchanged from the outside	Lithium, 950 mAh, exchanged from the outside
Real-time clock	Battery-buffered	Battery-buffered
Mode/node switches	2, 16 digits each	2, 16 digits each
<b>Display</b>	<b>4PP480.1505-75</b>	<b>4PP480.1505-B5</b>
Type	TFT color	TFT color
Colors	262,144 <sup>1)</sup>	262,144 <sup>1)</sup>
Resolution	XGA, 1024 x 768 pixels	XGA, 1024 x 768 pixels
Diagonal	15"	15"
Brightness	250 cd/m <sup>2</sup>	250 cd/m <sup>2</sup>
Half-brightness time	50,000 h	50,000 h
Touch screen	Analog resistive	Analog resistive
<b>Keys</b>	<b>4PP480.1505-75</b>	<b>4PP480.1505-B5</b>
Function keys	20, with LED	20, with LED
Soft keys	12, with LED	12, with LED
<b>Interfaces</b>	<b>4PP480.1505-75</b>	<b>4PP480.1505-B5</b>
Serial		
Type	RS232	RS232
Design	9-pin DSUB plug	9-pin DSUB plug
Electrical isolation	No	No
Max. baud rate	115 kBits/s	115 kBits/s
USB	2x USB 2.0, connection type A <sup>1)</sup>	2x USB 2.0, connection type A <sup>1)</sup>
Ethernet	RJ45 twisted pair (10 BaseT / 100 BaseT)	RJ45 twisted pair (10 BaseT / 100 BaseT)
<b>24 VDC supply</b>	<b>4PP480.1505-75</b>	<b>4PP480.1505-B5</b>
Input voltage	24 VDC ±25%, electrically isolated	24 VDC ±25%, electrically isolated
<b>Environmental conditions</b>	<b>4PP480.1505-75</b>	<b>4PP480.1505-B5</b>
Temperature		
Operation	0°C to +50°C	0°C to +50°C
Storage	-20°C to +60°C	-20°C to +60°C
Relative humidity		
Operation	5% to 85%, non-condensing	5% to 85%, non-condensing
Storage	T ≤ 40°C: 5% to 90%, non-condensing T > 40°C: < 90%, non-condensing	T ≤ 40°C: 5% to 90%, non-condensing T > 40°C: < 90%, non-condensing
<b>Mechanics</b>	<b>4PP480.1505-75</b>	<b>4PP480.1505-B5</b>
Protection type	IP65 (front side) / IP20 (back side)	IP65 (front side) / IP20 (back side)
Outer dimensions (W x H x D [mm])	435 x 330 x 87	435 x 330 x 87
Weight	6.5 kg	6.8 kg
<small>1) Automation Runtime limitation - max. 256 colors, USB 1.1</small>		
<b>Required accessories</b>		
	Network and fieldbus modules	▣ 611
	Lithium battery, 3 V / 950 mAh, button cell <sup>1)</sup>	▣ 1128
0TB103.9	Plug 24 VDC	▣ 1131
5AC900.150X-00	Legend strips for 15" panel, 1 sheet for labeling 4 panels. for Power Panel 4PPx80.1505-xx and 4PPx81.1505-xx devices	▣ 868
	CompactFlash cards	▣ 1126

1) Replacement part

# Power Panel PP451 embedded 10.4" TFT color



	4PP451.1043-75	4PP451.1043-B5
<b>Controller</b>	<b>4PP451.1043-75</b>	<b>4PP451.1043-B5</b>
Processor	Geode LX800 500 MHz, MMX compatible	Geode LX800 500 MHz, MMX compatible
Main memory	128 MB DRAM	128 MB DRAM
Graphics memory	8 MB shared memory (allocated from main memory)	8 MB shared memory (allocated from main memory)
SRAM	512 KB, battery-buffered	512 KB, battery-buffered
CompactFlash slot	1 slot for Type I CompactFlash card	1 slot for Type I CompactFlash card
aPCI slots	1	2
Watchdog	MTCX	MTCX
Power failure logic	MTCX 10 ms buffer time	MTCX 10 ms buffer time
Battery	Lithium, 950 mAh, exchanged from the outside	Lithium, 950 mAh, exchanged from the outside
Real-time clock	Battery-buffered	Battery-buffered
Mode/node switches	2, 16 digits each	2, 16 digits each
<b>Display</b>	<b>4PP451.1043-75</b>	<b>4PP451.1043-B5</b>
Type	TFT color	TFT color
Colors	262.144 <sup>1)</sup>	262.144 <sup>1)</sup>
Resolution	VGA, 640 x 480 pixels	VGA, 640 x 480 pixels
Diagonal	10.4"	10.4"
Brightness	450 cd/m <sup>2</sup>	450 cd/m <sup>2</sup>
Half-brightness time	55,000 h	55,000 h
Touch screen	-	-
<b>Keys</b>	<b>4PP451.1043-75</b>	<b>4PP451.1043-B5</b>
Function keys	28, with LED	28, with LED
Soft keys	10, with LED	10, with LED
System keys	Number block, cursor keys	Number block, cursor keys
<b>Interfaces</b>	<b>4PP451.1043-75</b>	<b>4PP451.1043-B5</b>
<b>Serial</b>		
Type	RS232	RS232
Design	9-pin DSUB plug	9-pin DSUB plug
Electrical isolation	No	No
Max. baud rate	115 kBits/s	115 kBits/s
<b>USB</b>		
Type	2x USB 2.0, connection type A <sup>1)</sup>	2x USB 2.0, connection type A <sup>1)</sup>
Ethernet	RJ45 twisted pair (10 BaseT / 100 BaseT)	RJ45 twisted pair (10 BaseT / 100 BaseT)
<b>24 VDC supply</b>	<b>4PP451.1043-75</b>	<b>4PP451.1043-B5</b>
Input voltage	24 VDC ±25%, electrically isolated	24 VDC ±25%, electrically isolated
<b>Environmental conditions</b>	<b>4PP451.1043-75</b>	<b>4PP451.1043-B5</b>
<b>Temperature</b>		
Operation	0 to +50°C	0 to +50°C
Storage	-20°C to +70°C	-20°C to +70°C
<b>Relative humidity</b>		
Operation	5% to 85%, non-condensing	5% to 85%, non-condensing
Storage	T ≤ 40°C: 5% to 90%, non-condensing T > 40°C: < 90%, non-condensing	T ≤ 40°C: 5% to 90%, non-condensing T > 40°C: < 90%, non-condensing
<b>Mechanics</b>	<b>4PP451.1043-75</b>	<b>4PP451.1043-B5</b>
Protection type	IP65 (front side) / IP20 (back side)	IP65 (front side) / IP20 (back side)
Outer dimensions (W x H x D [mm])	323 x 358 x 86	323 x 358 x 108
Weight	5.0 kg	5.3 kg
1) Automation Runtime limitation - max. 256 colors, USB 1.1		
<b>Required accessories</b>		
	Network and fieldbus modules	611
	Lithium battery, 3 V / 950 mAh, button cell <sup>1)</sup>	1128
	Plug 24 VDC	1131
5AC900.104X-00	Legend strips for 10.4" panel, 1 sheet for labeling 1 panel. For Power Panel 4PPx51.1043-xx and 4PPx81.1043-xx devices.	868
	CompactFlash cards	1126

1) Replacement part

# Power Panel PP481 embedded 10.4" TFT color touch screen



	4PP481.1043-75	4PP481.1043-B5
<b>Controller</b>	<b>4PP481.1043-75</b>	<b>4PP481.1043-B5</b>
Processor	Geode LX800 500 MHz, MMX compatible	Geode LX800 500 MHz, MMX compatible
Main memory	128 MB DRAM	128 MB DRAM
Graphics memory	8 MB shared memory (allocated from main memory)	8 MB shared memory (allocated from main memory)
SRAM	512 KB, battery-buffered	512 KB, battery-buffered
CompactFlash slot	1 slot for Type I CompactFlash card	1 slot for Type I CompactFlash card
aPCI slots	1	2
Watchdog	MTCX	MTCX
Power failure logic	MTCX 10 ms buffer time	MTCX 10 ms buffer time
Battery	Lithium, 950 mAh, exchanged from the outside	Lithium, 950 mAh, exchanged from the outside
Real-time clock	Battery-buffered	Battery-buffered
Mode/node switches	2, 16 digits each	2, 16 digits each
<b>Display</b>	<b>4PP481.1043-75</b>	<b>4PP481.1043-B5</b>
Type	TFT color	TFT color
Colors	262.144 <sup>1)</sup>	262.144 <sup>1)</sup>
Resolution	VGA, 640 x 480 pixels	VGA, 640 x 480 pixels
Diagonal	10.4"	10.4"
Brightness	450 cd/m <sup>2</sup>	450 cd/m <sup>2</sup>
Half-brightness time	55,000 h	55,000 h
Touch screen	Analog resistive	Analog resistive
<b>Keys</b>	<b>4PP481.1043-75</b>	<b>4PP481.1043-B5</b>
Function keys	28, with LED	28, with LED
Soft keys	10, with LED	10, with LED
System keys	Number block, cursor keys	Number block, cursor keys
<b>Interfaces</b>	<b>4PP481.1043-75</b>	<b>4PP481.1043-B5</b>
Serial		
Type	RS232	RS232
Design	9-pin DSUB plug	9-pin DSUB plug
Electrical isolation	No	No
Max. baud rate	115 kBits/s	115 kBits/s
USB	2x USB 2.0, connection type A <sup>1)</sup>	2x USB 2.0, connection type A <sup>1)</sup>
Ethernet	RJ45 twisted pair (10 BaseT / 100 BaseT)	RJ45 twisted pair (10 BaseT / 100 BaseT)
<b>24 VDC supply</b>	<b>4PP481.1043-75</b>	<b>4PP481.1043-B5</b>
Input voltage	24 VDC ±25%, electrically isolated	24 VDC ±25%, electrically isolated
<b>Environmental conditions</b>	<b>4PP481.1043-75</b>	<b>4PP481.1043-B5</b>
Temperature		
Operation	0 to +50°C	0 to +50°C
Storage	-20°C to +70°C	-20°C to +70°C
Relative humidity		
Operation	5% to 85%, non-condensing	5% to 85%, non-condensing
Storage	T ≤ 40°C: 5% to 90%, non-condensing T > 40°C: < 90%, non-condensing	T ≤ 40°C: 5% to 90%, non-condensing T > 40°C: < 90%, non-condensing
<b>Mechanics</b>	<b>4PP481.1043-75</b>	<b>4PP481.1043-B5</b>
Protection type	IP65 (front side) / IP20 (back side)	IP65 (front side) / IP20 (back side)
Outer dimensions (W x H x D [mm])	323 x 358 x 86	323 x 358 x 108
Weight	5.0 kg	5.3 kg

1) Automation Runtime limitation - max. 256 colors, USB 1.1

Required accessories		
Network and fieldbus modules		611
Lithium battery, 3 V / 950 mAh, button cell <sup>1)</sup>		1128
Plug 24 VDC		1131
5AC900.104X-00	Legend strips for 10.4" panel, 1 sheet for labeling 1 panel. For Power Panel 4PPx51.1043-xx and 4PPx81.1043-xx devices.	868
CompactFlash cards		1126

1) Replacement part

# Power Panel PP481 embedded 15.0" TFT color touch screen



<b>Controller</b>		<b>4PP481.1505-75</b>
Processor	Geode LX800 500 MHz, MMX compatible	
Main memory	128 MB DRAM	
Graphics memory	8 MB shared memory (allocated from main memory)	
SRAM	512 KB, battery-buffered	
CompactFlash slot	1 slot for Type I CompactFlash card	
aPCI slots	1	
Watchdog	MTCX	
Power failure logic	MTCX 10 ms buffer time	
Battery	Lithium, 950 mAh, exchanged from the outside	
Real-time clock	Battery-buffered	
Mode/node switches	2, 16 digits each	
<b>Display</b>		<b>4PP481.1505-75</b>
Type	TFT color	
Colors	262.144 <sup>1)</sup>	
Resolution	XGA, 1024 x 768 pixels	
Diagonal	15.0"	
Brightness	450 cd/m <sup>2</sup>	
Half-brightness time	50,000 h	
Touch screen	Analog resistive	
<b>Keys</b>		<b>4PP481.1505-75</b>
Function keys	20, with LED	
Soft keys	12, with LED	
System keys	Alphanumeric keys Number block, cursor keys	
<b>Interfaces</b>		<b>4PP481.1505-75</b>
Serial		
Type	RS232	
Design	9-pin DSUB plug	
Electrical isolation	No	
Max. baud rate	115 kBits/s	
USB	2x USB 2.0, connection type A <sup>1)</sup>	
Ethernet	RJ45 twisted pair (10 BaseT / 100 BaseT)	
<b>24 VDC supply</b>		<b>4PP481.1505-75</b>
Input voltage	24 VDC ±25%, electrically isolated	
<b>Environmental conditions</b>		<b>4PP481.1505-75</b>
Temperature		
Operation	0 to +50°C	
Storage	-20°C to +60°C	
Relative humidity		
Operation	5% to 85%, non-condensing	
Storage	T ≤ 40°C: 5% to 90%, non-condensing T > 40°C: < 90%, non-condensing	
<b>Mechanics</b>		<b>4PP481.1505-75</b>
Protection type	IP65 (front side) / IP20 (back side)	
Outer dimensions (W x H x D [mm])	435 x 430 x 87	
Weight	8.0 kg	
1) Automation Runtime limitation - max. 256 colors, USB 1.1		
<b>Required accessories</b>		
	Network and fieldbus modules	▣ 611
	Lithium battery, 3 V / 950 mAh, button cell <sup>1)</sup>	▣ 1128
	Plug 24 VDC	▣ 1131
5AC900.150X-00	Legend strips for 15" panel, 1 sheet for labeling 4 panels. for Power Panel 4PPx80.1505-xx and 4PPx81.1505-xx devices	▣ 868
	CompactFlash cards	▣ 1126

1) Replacement part

# Power Panel PP452 embedded 10.4" TFT color



<b>Controller</b>		<b>4PP452.1043-75</b>
Processor	Geode LX800 500 MHz, MMX compatible	
Main memory	128 MB DRAM	
Graphics memory	8 MB shared memory (allocated from main memory)	
SRAM	512 KB, battery-buffered	
CompactFlash slot	1 slot for Type I CompactFlash card	
aPCI slots	1	
Watchdog	MTCX	
Power failure logic	MTCX 10 ms buffer time	
Battery	Lithium, 950 mAh, exchanged from the outside	
Real-time clock	Battery-buffered	
Mode/node switches	2, 16 digits each	
<b>Display</b>		<b>4PP452.1043-75</b>
Type	TFT color	
Colors	262.144 <sup>1)</sup>	
Resolution	VGA, 640 x 480 pixels	
Diagonal	10.4"	
Brightness	450 cd/m <sup>2</sup>	
Half-brightness time	55,000 h	
Touch screen	-	
<b>Keys</b>		<b>4PP452.1043-75</b>
Function keys	44	
System keys	Number block Cursor keys	
<b>Interfaces</b>		<b>4PP452.1043-75</b>
Serial		
Type	RS232	
Design	9-pin DSUB plug	
Electrical isolation	No	
Max. baud rate	115 kBits/s	
USB	2x USB 2.0, connection type A <sup>1)</sup>	
Ethernet	RJ45 twisted pair (10 BaseT / 100 BaseT)	
<b>24 VDC supply</b>		<b>4PP452.1043-75</b>
Input voltage	24 VDC ±25%, electrically isolated	
<b>Environmental conditions</b>		<b>4PP452.1043-75</b>
Temperature		
Operation	0 to +50°C	
Storage	-20°C to +70°C	
Relative humidity		
Operation	5% to 85%, non-condensing	
Storage	T ≤ 40°C: 5% to 90%, non-condensing T > 40°C: < 90%, non-condensing	
<b>Mechanics</b>		<b>4PP452.1043-75</b>
Protection type	IP65 (front side) / IP20 (back side)	
Outer dimensions (W x H x D [mm])	423 x 288 x 86	
Weight	5.2 kg	
1) Automation Runtime limitation - max. 256 colors, USB 1.1		
<b>Required accessories</b>		
	Network and fieldbus modules	▣ 611
	Lithium battery, 3 V / 950 mAh, button cell <sup>1)</sup>	▣ 1128
	Plug 24 VDC	▣ 1131
5AC900.104X-01	Legend strips for 10.4" panel, 1 sheet for labeling 1 panels. for Power Panel 4PPx52.1043-xx and 4PPx82.1043-xx devices	▣ 868
	CompactFlash cards	▣ 1126

1) Replacement part

# Power Panel PP482 embedded 10.4" TFT color touch screen



<b>Controller</b>		<b>4PP482.1043-75</b>
Processor	Geode LX800 500 MHz, MMX compatible	
Main memory	128 MB DRAM	
Graphics memory	8 MB shared memory (allocated from main memory)	
SRAM	512 KB, battery-buffered	
CompactFlash slot	1 slot for Type I CompactFlash card	
aPCI slots	1	
Watchdog	MTCX	
Power failure logic	MTCX 10 ms buffer time	
Battery	Lithium, 950 mAh, exchanged from the outside	
Real-time clock	Battery-buffered	
Mode/node switches	2, 16 digits each	
<b>Display</b>		<b>4PP482.1043-75</b>
Type	TFT color	
Colors	262.144 <sup>1)</sup>	
Resolution	VGA, 640 x 480 pixels	
Diagonal	10.4"	
Brightness	450 cd/m <sup>2</sup>	
Half-brightness time	55,000 h	
Touch screen	Analog resistive	
<b>Keys</b>		<b>4PP482.1043-75</b>
Function keys	44	
System keys	Number block Cursor keys	
<b>Interfaces</b>		<b>4PP482.1043-75</b>
Serial		
Type	RS232	
Design	9-pin DSUB plug	
Electrical isolation	No	
Max. baud rate	115 kBits/s	
USB	2x USB 2.0, connection type A <sup>1)</sup>	
Ethernet	RJ45 twisted pair (10 BaseT / 100 BaseT)	
<b>24 VDC supply</b>		<b>4PP482.1043-75</b>
Input voltage	24 VDC ±25%, electrically isolated	
<b>Environmental conditions</b>		<b>4PP482.1043-75</b>
Temperature		
Operation	0 to +50°C	
Storage	-20°C to +70°C	
Relative humidity		
Operation	5% to 85%, non-condensing	
Storage	T ≤ 40°C: 5% to 90%, non-condensing T > 40°C: < 90%, non-condensing	
<b>Mechanics</b>		<b>4PP482.1043-75</b>
Protection type	IP65 (front side) / IP20 (back side)	
Outer dimensions (W x H x D [mm])	423 x 288 x 86	
Weight	5.2 kg	
1) Automation Runtime limitation - max. 256 colors, USB 1.1		
<b>Required accessories</b>		
	Network and fieldbus modules	611
	Lithium battery, 3 V / 950 mAh, button cell <sup>1)</sup>	1128
	Plug 24 VDC	1131
5AC900.104X-01	Legend strips for 10.4" panel, 1 sheet for labeling 1 panels. for Power Panel 4PPx52.1043-xx and 4PPx82.1043-xx devices	868
	CompactFlash cards	1126

1) Replacement part





# Dimensions

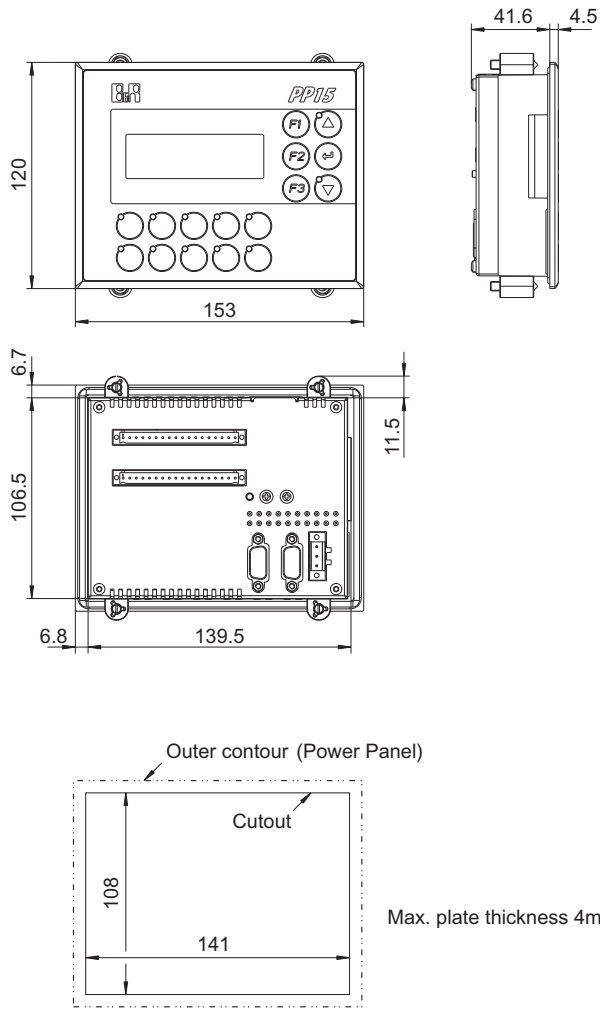

Max. plate thickness 4mm

PP 15/35 dimensions

All dimensions in mm

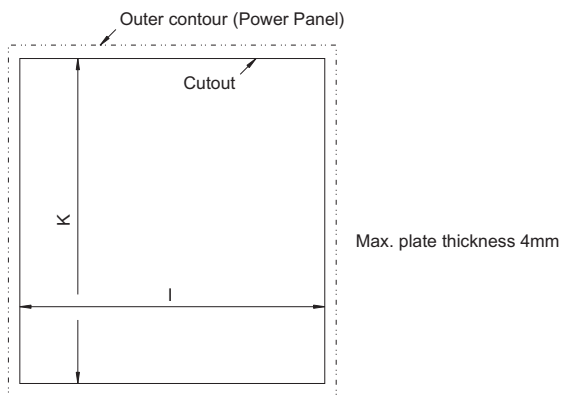
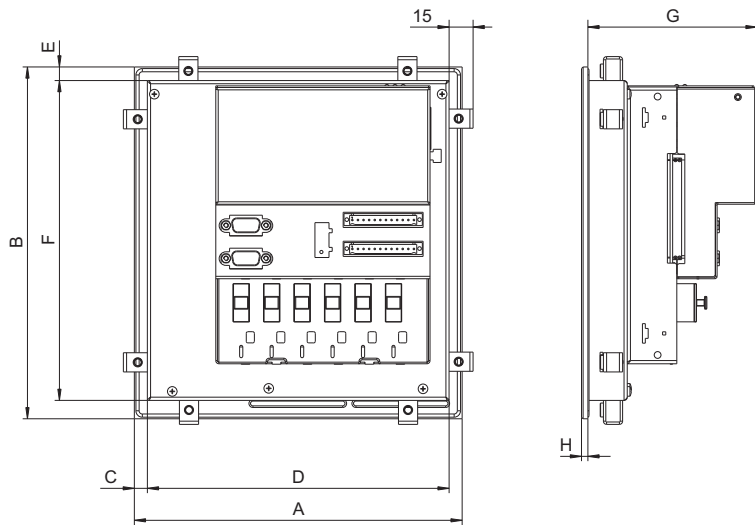

PP 21/41 dimensions

Model number	A	B	C	D	E	F	G	H	I	K
4P0420.00-490	155	190	10	134	8.1	173.8	81.2	4	138	179
4P3040.01-490	205	220	8	188.7	10	200	105.8	4	192	205

All dimensions in mm

# Dimensions

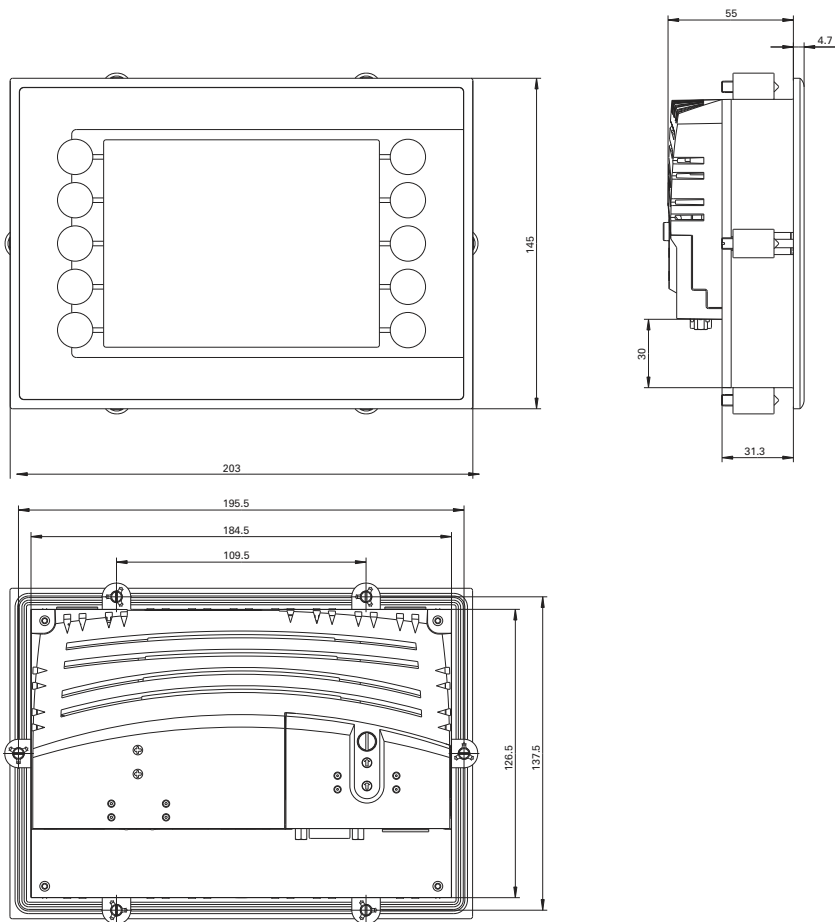

PP45 dimensions

All dimensions in mm

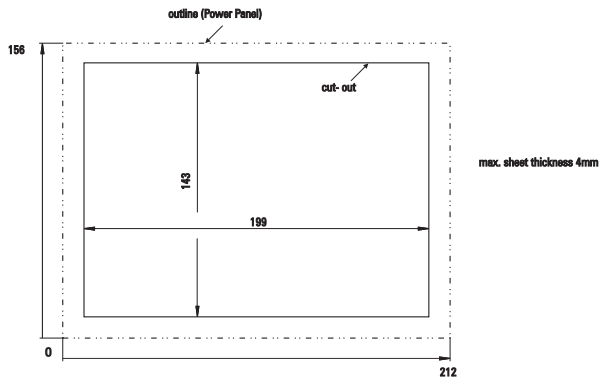
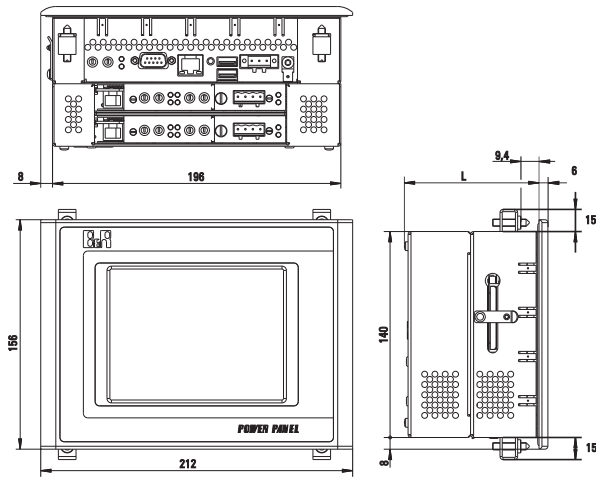

Power Panel dimensions

Model number	aPCI slots	L
4PP320.0571-01	0	49.5
4PP320.0571-35	0	49.5
4PP420.0571-45	1	70
4PP420.0571-75	1	70
4PP420.0571-85	2	92
4PP420.0571-B5	2	92
4PP420.0573-75	1	70
5PP320.0571-39	0	49.5
5PP320.0573-39	0	49.5
5PP320.0573-3B	0	49.5

All dimensions in mm

# Dimensions

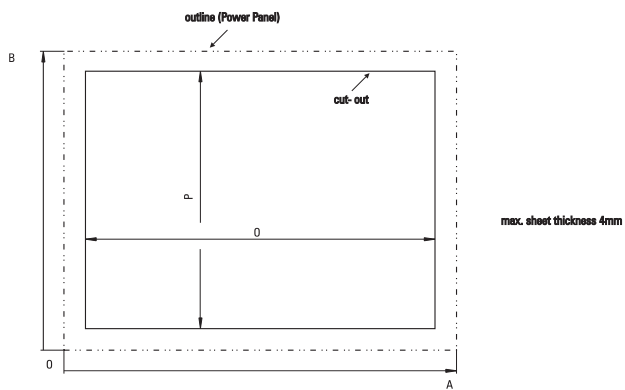
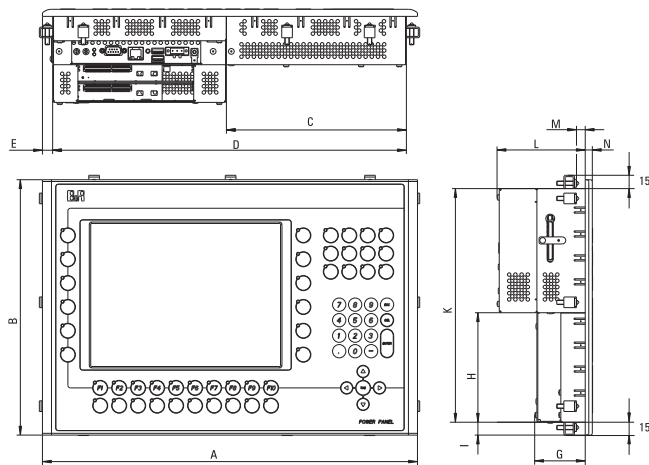

Power Panel dimensions

All dimensions in mm

Model number	A	B	C	D	E	G	H	I	K	L	M	N	O	P
4PP320.1043-31	323	260	104	300	11.5	57.5	100	10	240	57.5	9.9	8	303	243
4PP320.1505-31	435	330	216	412	11.6	63.5	169	10.5	309	63.5	9.9	8	414.8	312
4PP352.0571-35	302	187	-	286	8	50	-	8	171	50	11.9	6	289	174
4PP381.1043-31	323	358	-	300	11.5	57.5	-	15	333	57.5	9.9	8	303	336
4PP420.1043-75	323	260	104	300	11.5	57.5	100	10	240	78	9.9	8	303	243
4PP420.1043-B5	323	260	104	300	11.5	57.5	100	10	240	100	9.9	8	303	243
4PP420.1505-75	435	330	216	412	11.6	58.5	169	10.5	309	79	9.9	8	414.8	312
4PP420.1505-B5	435	330	216	412	11.6	58.5	169	10.5	309	101	9.9	8	414.8	312
4PP451.1043-75	323	358	104	300	11.5	57.5	193	15	333	78	9.9	8	303	336
4PP451.1043-B5	323	358	104	300	11.5	57.5	193	15	333	100	9.9	8	303	336
4PP452.0571-45	302	187	90	286	8	50	31	8	171	70	11.9	6	289	174
4PP452.0571-75	302	187	90	286	8	50	31	8	171	70	11.9	6	289	174
4PP452.0571-B5	302	187	90	286	8	50	31	8	171	92	11.9	6	289	174
4PP452.1043-75	423	288	203	399	11.5	57.5	123.5	14.5	263.5	78	9.9	8	402	266.5
4PP480.1043-75	323	260	104	300	11.5	57.5	100	10	240	78	9.9	8	303	243
4PP480.1505-75	435	330	216	412	11.6	58.5	169	10.5	309	79	9.9	8	414.8	312
4PP480.1505-B5	435	330	216	412	11.6	58.5	169	10.5	309	79	9.9	8	414.8	312
4PP481.1043-75	323	358	104	300	11.5	57.5	193	15	333	78	9.9	8	303	336
4PP481.1043-B5	323	358	104	300	11.5	57.5	193	15	333	100	9.9	8	303	336
4PP481.1505-75	435	430	216	412	11.6	58.5	269.5	10	409.5	79	9.9	8	414.8	412
4PP482.1043-75	423	288	203	399	11.5	57.5	123.5	14.5	263.5	78	9.9	8	402	266.5
5PP320.1043-39	323	260	104	300	11.5	57.5	100	10	240	57.5	9.9	8	303	243
5PP320.1214-39	362	284	146	342	10	57.5	123.9	10	264	57.5	9.9	8	345	267
5PP320.1505-39	435	330	216	412	11.6	55.5	169	10.5	309	63.5	9.9	8	414.8	312

All dimensions in mm

# Dimensions

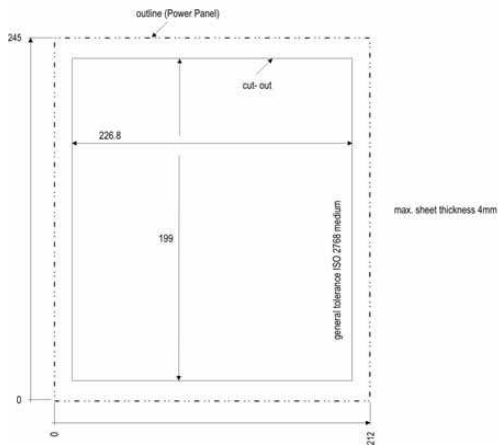
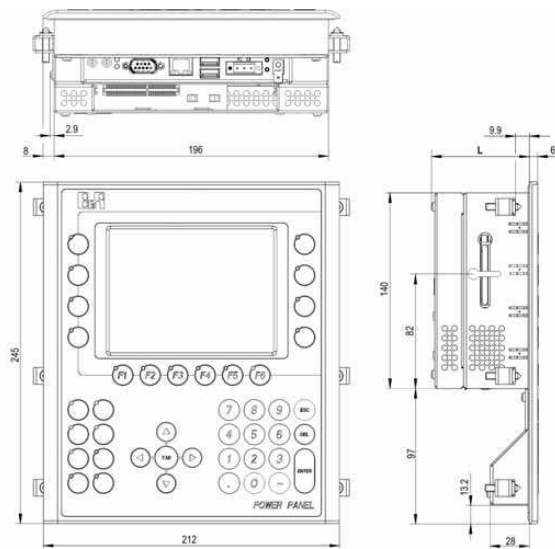

Power Panel dimensions

Model number	aPCI slots	L
4PP351.0571-01	0	49.5
4PP351.0571-35	0	49.5
4PP451.0571-45	1	70
4PP451.0571-75	1	70
4PP451.0571-85	1	92
4PP451.0571-B5	1	92

All dimensions in mm





# Legend strips

Model number	Short description
5AC900.057X-00	5.7" legend strip template for Power Panel 4PP351.0571-01, 4PP351.0571-35, 4PP451.0571-45, 4PP451.0571-85, 4PP451.0571-75, 4PP451.0571-B5. For 3 devices.

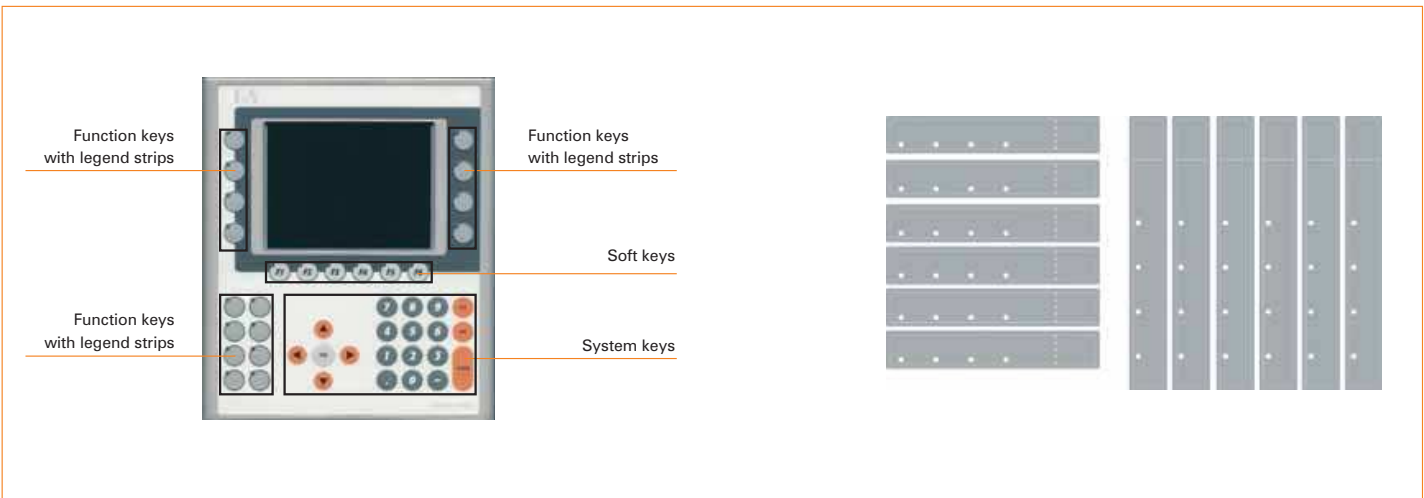

Model number	Short description
5AC900.057X-01	5.7" legend strip template for Power Panel 4PP352.0571-35, 4PP452.0571-45, 4PP452.0571-75, 4PP452.0571-B5. For 3 devices.

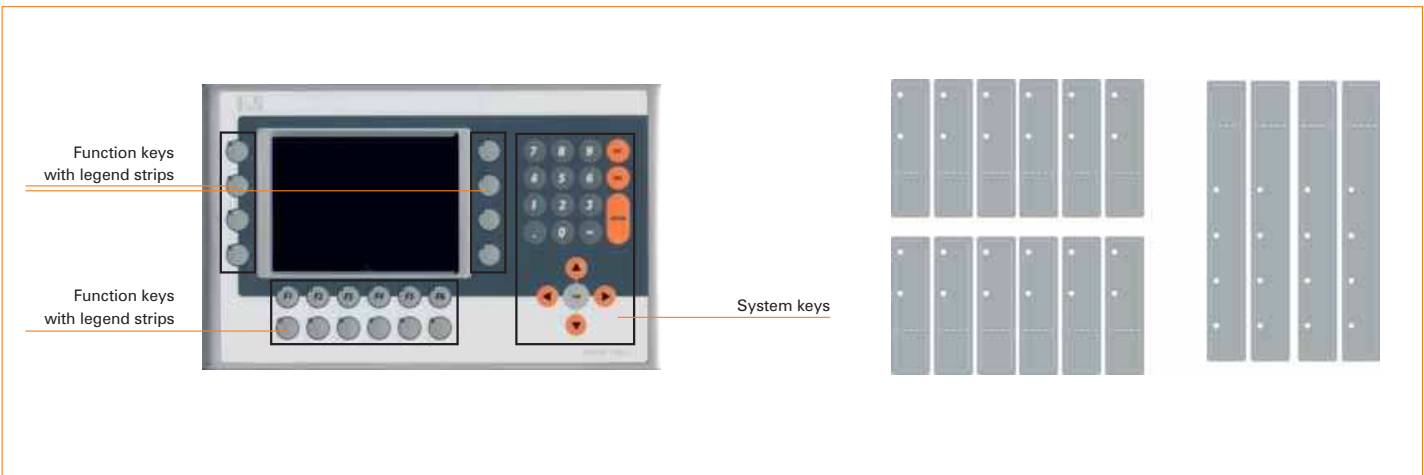

Model number	Short description
5AC900.104X-00	10.4" legend strip template for Power Panel 4PP381.1043-31, 4PP451.1043-75, 4PP451.1043-B5, 4PP481.1043-75, 4PP481.1043-B5. For Panel PC 5PC781.1043-00. For 1 device.

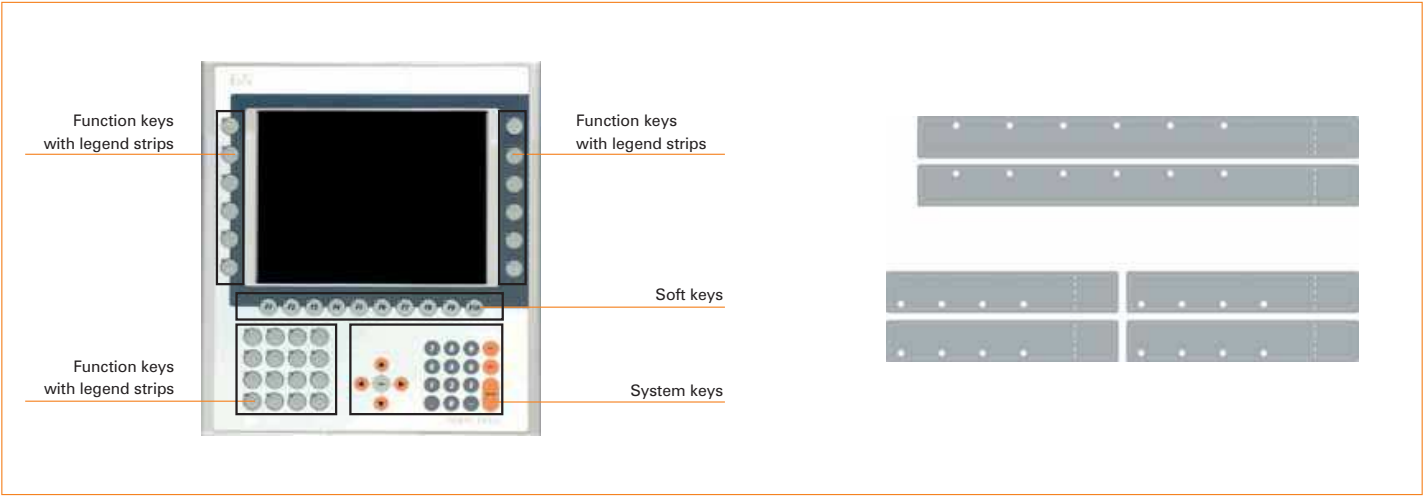

Model number	Short description
5AC900.104X-01	10.4" legend strip template for Power Panel 4PP452.1043-75, 4PP482.1043-B5, 4PP482.1043-75. For Panel PC 5PC782.1043-00. For 1 device.

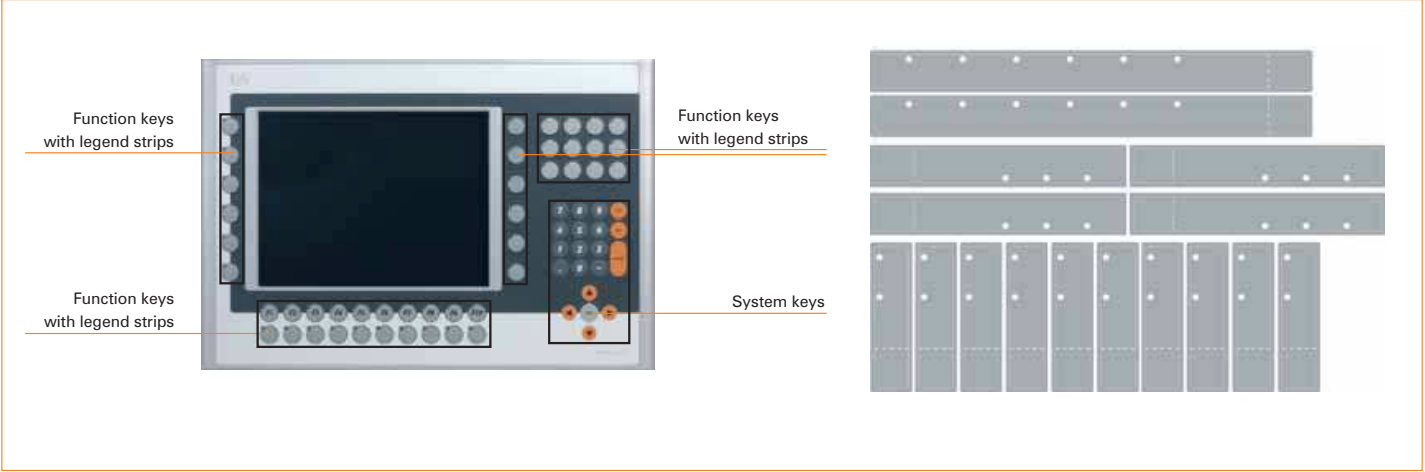

# Legend strips

Model number	Short description
5AC900.104X-02	10.4" legend strip template for Power Panel 4PP480.1043-75. For 3 devices.

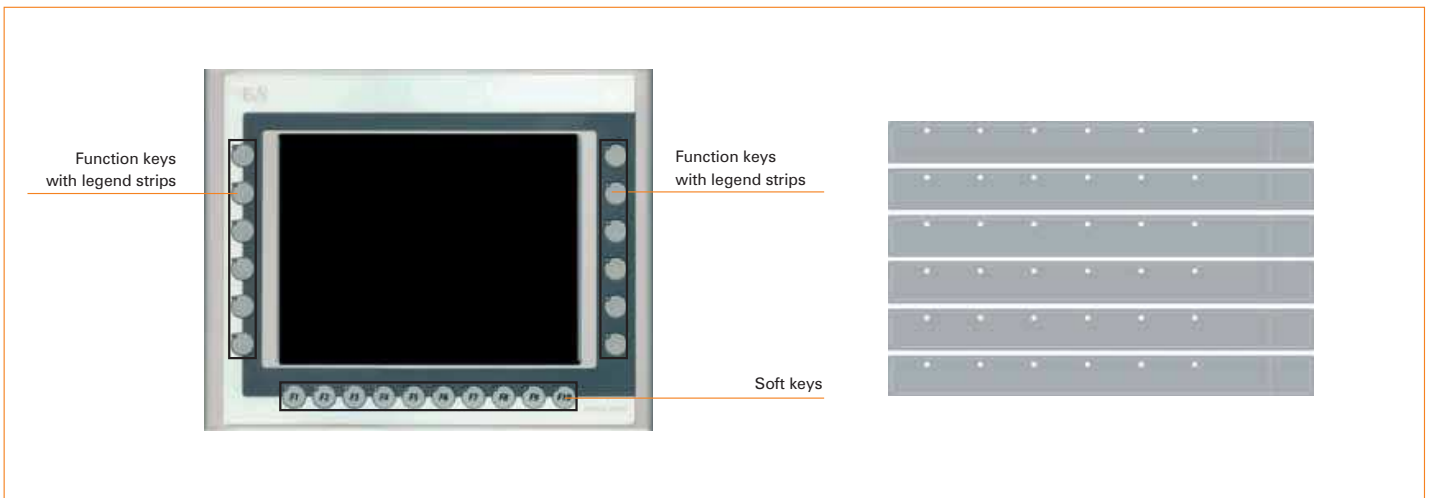

Model number	Short description
5AC900.150X-00	15" legend strip template for Power Panel 4PP480.1505-75, 4PP480.1505-B5, 4PP481.1505-75. For 4 devices.

