

NC Specifications / FANUC Series

	Item	Specification	0i-TD
Controlled axis	Max. feed axes		4 AXIS
	Feed axes		X/Z/(Cs)
	Max. simultaneously controlled axis		4
	Least command increment	0.001mm / 0.0001"	○
Operation functions	Pulse handle feed	X1, X10, X100	○
	Feedrate per minute	G98	○
	Feedrate per revolution	G99	○
Interpolation functions	Linear interpolation	G01	○
	Circular interpolation	G02, G03	○
	Dwell	G04	○
	Polar coordinate interpolation	G12.1, G13.1	○
	Cylindrical interpolation	G70.1	○
	Variable lead thread cutting	G34	○
	Continuous threading		○
	Reference position return	G28	○
Feed function	Reference position return check	G27	○
	Rapid traverse rate override	F0, 25%, 50%, 100%	○
Spindle function	Feedrate override		0~150%
	Spindle orientation		○
Tool functions	Rigid tapping		○
	Tool number command	T4-Digt / T2-Digt	T4-Digt
	Tool nose radius compensation	G40 ~ G42	○
	Tool offset pairs		○
	Tool geometry/wear offset	GEOMETRY & WEAR DATA	○
	Tool life management		○
	Tool path graphic display		○
	Automatic tool offset	G36, G37	○
Program input	Direct input of tool offset value measured B		○
	Absolute/incremental programming		○
	Multiple repetitive cycle	G70 ~ G76	○
	Canned cycles	G90, G92, G94	○
	Inch/metric conversion	G20 / G21	○
	Program restart		○
	Retraction for rigid tapping		○
	Max. programmable dimension	±99999.999mm/±9999.9999"	○
	M function	M3 digit	○
	Custom macro		○
	Canned cycle for drilling		○
	Direct drawing dimension programming		○
	Programmable data input	G10	○
	Optional block skip		○
Workpiece coordinate system	G52 ~ G59	○	
Setting and display	Number of registerable programs		400EA
	Alarm & Operator history display	ALARM & OPERATION DISPLAY	○
	Run hour and parts count display	RUNNING TIME & PART NO. DISPLAY	○
	Display spindle & servo overload	SPINDLE & SERVO LOAD DISPLAY	○
	Self-diagnosis function		○
	Extended part program editing	COPY, MOVE, CHANGE OF NC PROGRAM	○
Data input/output	Display screen		10.4" color
	Memory card input/output		○
Editing operation	USB memory input/output		○
	Part program storage size	512Kbyte(1280m)	○
Manual guide i	Manual Guide i		○

SMEC

PL 60 series

HORIZONTAL TURNING CENTER



SMEC
SMEC CO.,LTD.

SMEC Co., Ltd.

157-10, Goldenroot-ro, Juchon-myeon, Gimhae-si, Gyeongsangnam-do, Korea

Tel +82 55 340 4800 Fax +82 55 340 4740

<http://www.esmec.com>



SMEC
SMEC CO.,LTD.

- 1988 - Started as Samsung Heavy Industries Machine Tools Business
- 1989 - Horizontal and vertical machining center technology partnership with OKK Japan
- 1991 - Turning center and vertical machining center technology partnership with Mori Seiki
- 1996 - 5-sided processing center technology partnership with Toshiba
- 1999 - Spun out from Samsung Aerospace Industries and established SMEC Co., Ltd

SMEC

Company
Engineering
Machine Tools
Samsung

PL 60/60M/60X/60XM PL 60L/60LM/60XL/60XLM

Strongest in class with superb structural design
Simultaneous heavy duty and precision turning

- 45 degree torque tube type bed to support heavy duty turning
- Significantly reduced non-cutting time and efficient turning
- Low-center of gravity reducing vibration, thermal deformation and improving rigidity

High Accuracy, High Rigidity Spindle

Main Spindle Motor and Gearing Headstock

The main spindle motor(45kW) speed is reduced to 2.5:1 and its power is delivered to the spindle through a three-speed geared headstock to provide powerful torque(560.7kg.m)

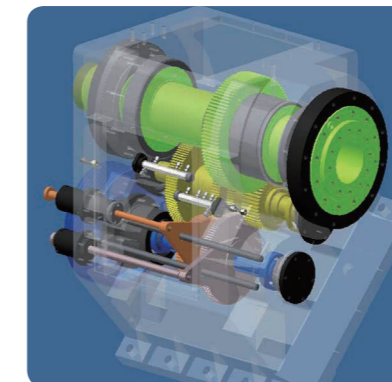
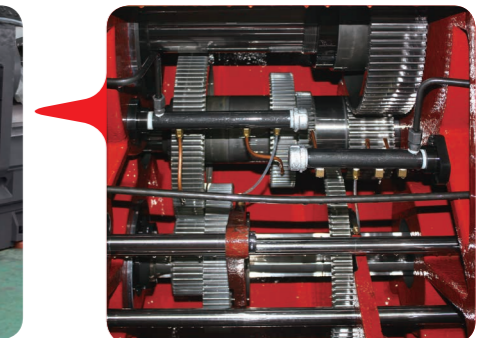
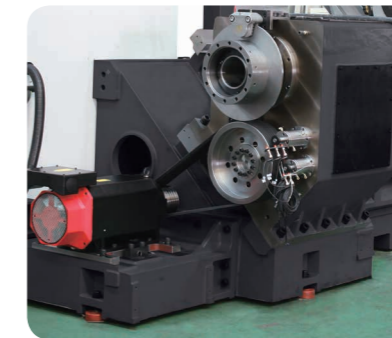

One Body Spindle and Headstock Construction for Minimal Thermal Expansion

The main spindle motor(45kW) speed is reduced to 2.5:1 and its power is delivered to the spindle through a three-speed geared headstock to provide powerful torque(560.7kg.m)

Spindle Power & Torque Diagram SL65, 65MC(24"Chuck)

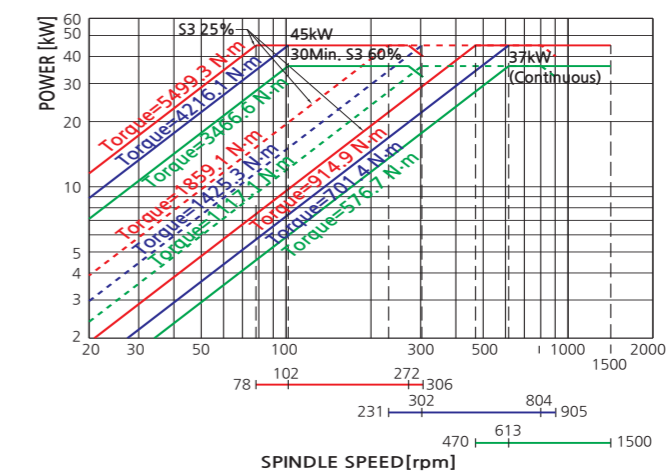

PL 60 series

HORIZONTAL TURNING CENTER

An innovative high precision, heavy duty CNC Lathe, integrated with all of SMEC's advanced technology - **PL 60 series**

Spindle speed
1,500 rpm

Spindle motor(30min/cont.)
45/37 kW

Rapid traverse(X/Z)
12/18 m/min (PL 60/60M/60XL/60XLM)
12/15 m/min (PL 60X/60XM)
12/10 m/min (PL 60L/60LM)

Feed motor(X/Z)
4/9 kW

Max. machining length
1,000 mm (PL 60/60M)
2,070 mm (PL 60X/60XM)
3,200 mm (PL 60L/60LM)
5,050 mm (PL 60XL/60XLM)

Max. machining diameter
900 mm

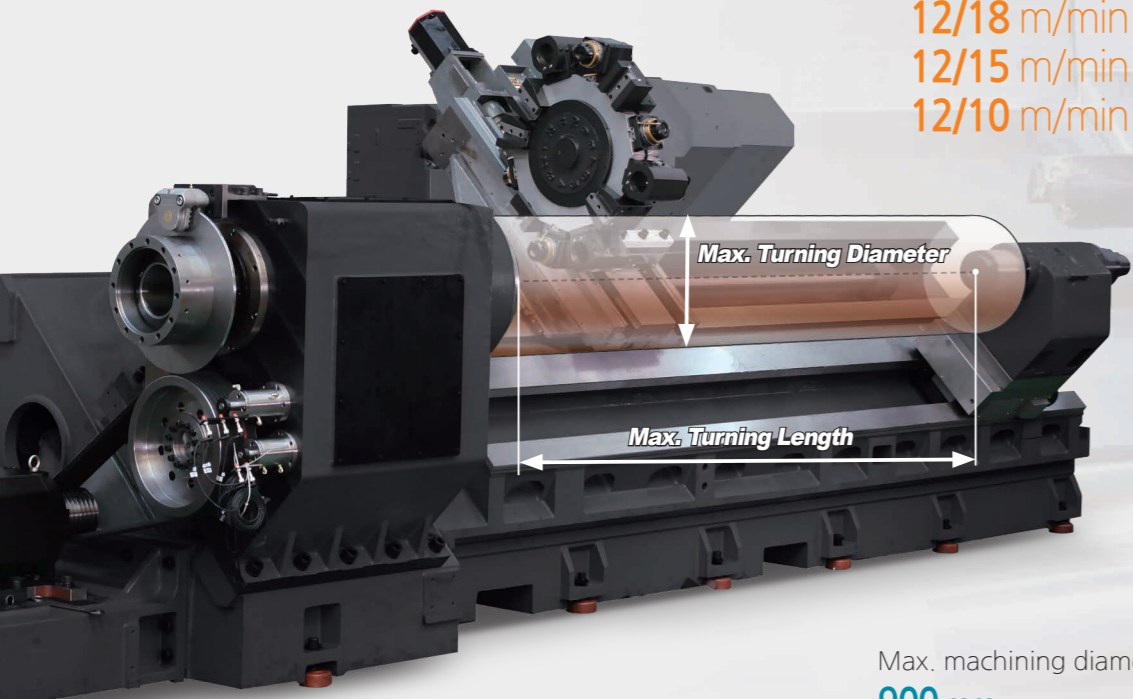

Highly Reliable and Rigid Structural Design

- One piece Meehanite casting with heavily ribbed torque tube design
- Rigid bed supports for powerful cutting
- Excellent vibration dampening and thermal displacement design

PL 60 (High Speed Servo Index Hydraulic Turret)

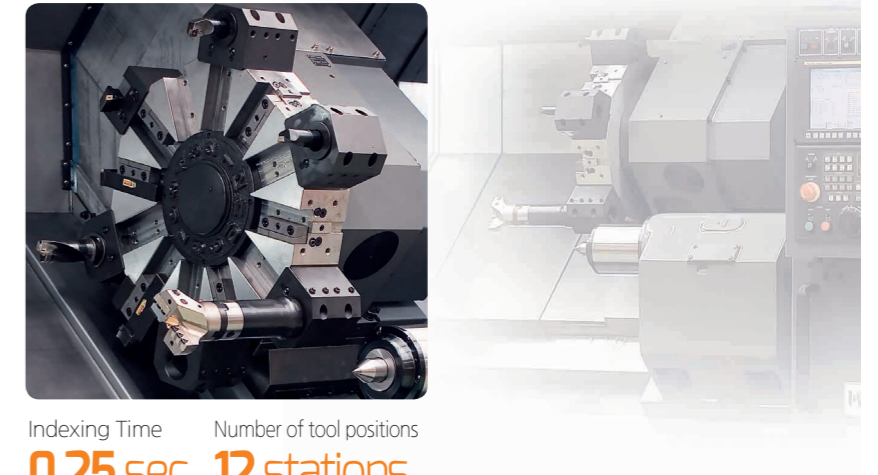

Indexing Time Number of tool positions
0.25 sec **12 stations**

High Speed, Heavy Duty Servo Turret

Driven by a high torque servo motor, the 12-station heavy -duty turret can accept tools on both left and right side of each station. Turret indexing (repeatability ± 0.01) is non-stop, bi-directional with a fast 0.25 second next station index time. Large diameter ($\varnothing 287$) precision Curvic coupling with 18,225kgf clamping force enables precision as well as heavy-duty cutting.

PL 60M (BMT High Speed Turret)

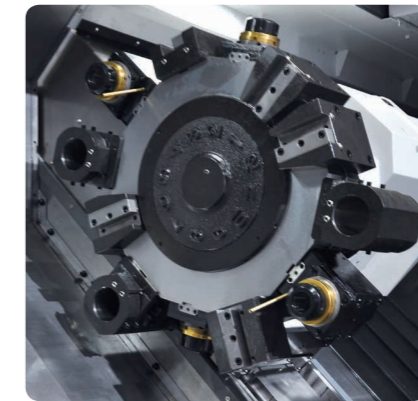

Turret Torque Diagram

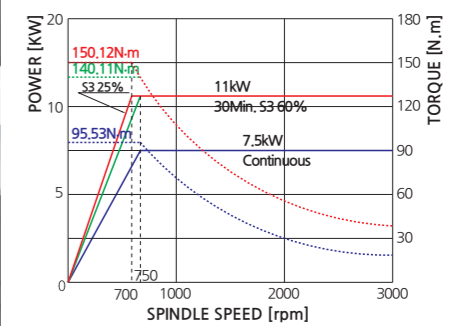

Indexing Time Number of tool positions Milling Spindle Speed Tool Holder
0.25 sec **12 stations** **3,000 rpm** **BMT 85**

BMT Milling Turret (M Type)

PL60M is equipped with standard 12-station BMT turret capable of accepting rotary tools at any station, providing flexible machining thru various machining operations in just one set-up. Each BMT holder is securely tightened by 4 screws, allowing the turret to perform heavy-duty cutting, milling and drilling operations. Turret indexing is non-stop, bi-directional with a fast 0.25 second next station index time.

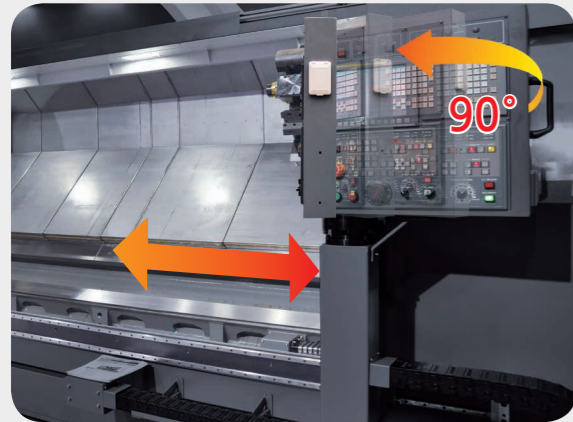

Centralized Operation Panel

The centralized operation panel with its 10.4 inch color TFT LCD monitor is able to swivel 90 degrees, providing operators with easy access to the control panel while working on the machine.



Rigid 45 degree Slant Bed

45 degree slant torque tube design bed and wide guide slide way ensure long term rigidity and machining accuracy. Also, the Slant Type structure allows for easier access to the workpiece and superb chip discharge.

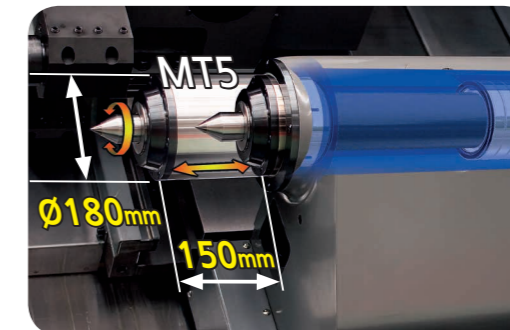
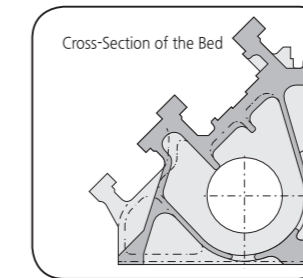

Programmable Tailstock (Carriage direct-coupled) [Std.]

The programmable tailstock body mounted is on wide guide ways to ensure rigid work piece support.

Pre-tensioned and Double Anchored Ballscrews

All axes ballscrews are pre-tensioned, heat treated and fixed by double anchors on both ends, providing ultimate rigidity and minimal thermal growth.

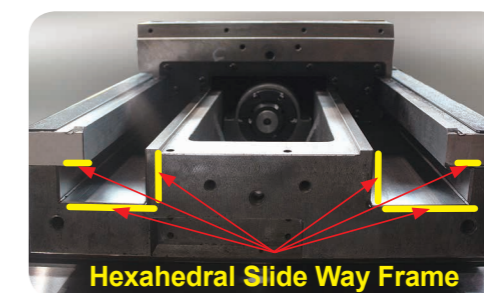
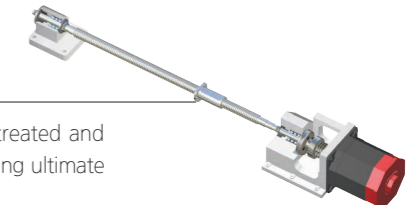

Hexahedral Slide Way Frame (X-axis)

Wide integral way is machined from the casting, induction hardened and precision ground to ensure long-term rigidity, machining accuracy and heavy-duty machining.

High Precision

Surface Roughness

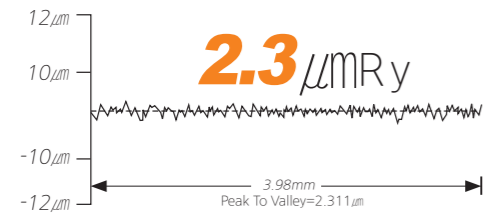

Model : PL 60L

Roundness

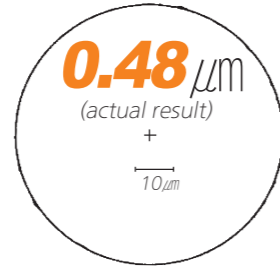

Cutting condition	
Tool	Diamond tool <nose radius 0.5mm>
Material	AL150<Aluminum>
Cutting speed	230 m/min
Feedrate	0.05 mm/rev
Depth of cut	0.1 mm
Outer diameter	200 mm
Filter	1-50

Processing Speed

Turning Performance (material:SM45C) PL 60L

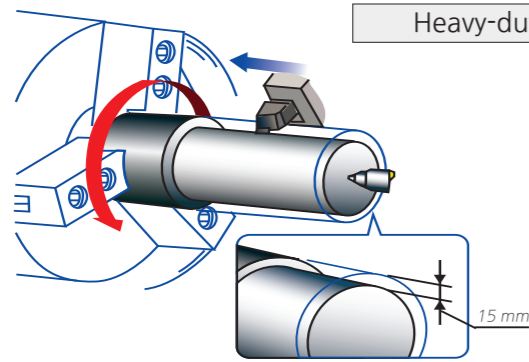

Heavy-duty cutting (O.D) <32mm×32mm qualified tool>

Spindle speed
367 rpm
Cutting speed
150 m/min
Depth of cut
15 mm <Spindle Load 65%>
Feedrate
0.4 mm/rev

Standard Accessories

Optional Accessories



Automatic Lubricator

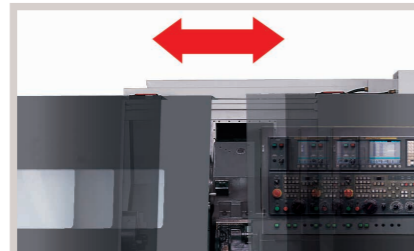

Auto Door

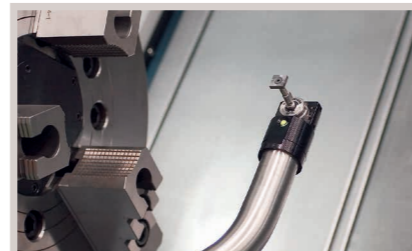

Tool Presetter

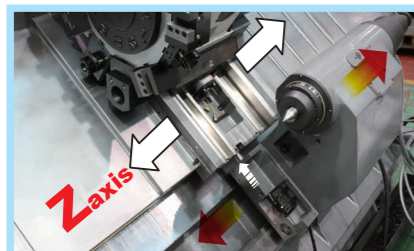

Programmable Tailstock



Chip Conveyor

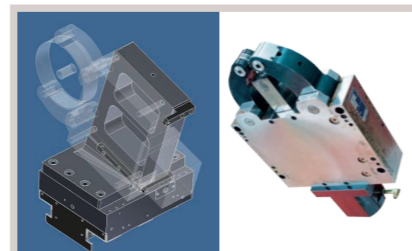

Steady Rest & Preparation

Tooling System

PL 60 / 60X / 60L / 60XL

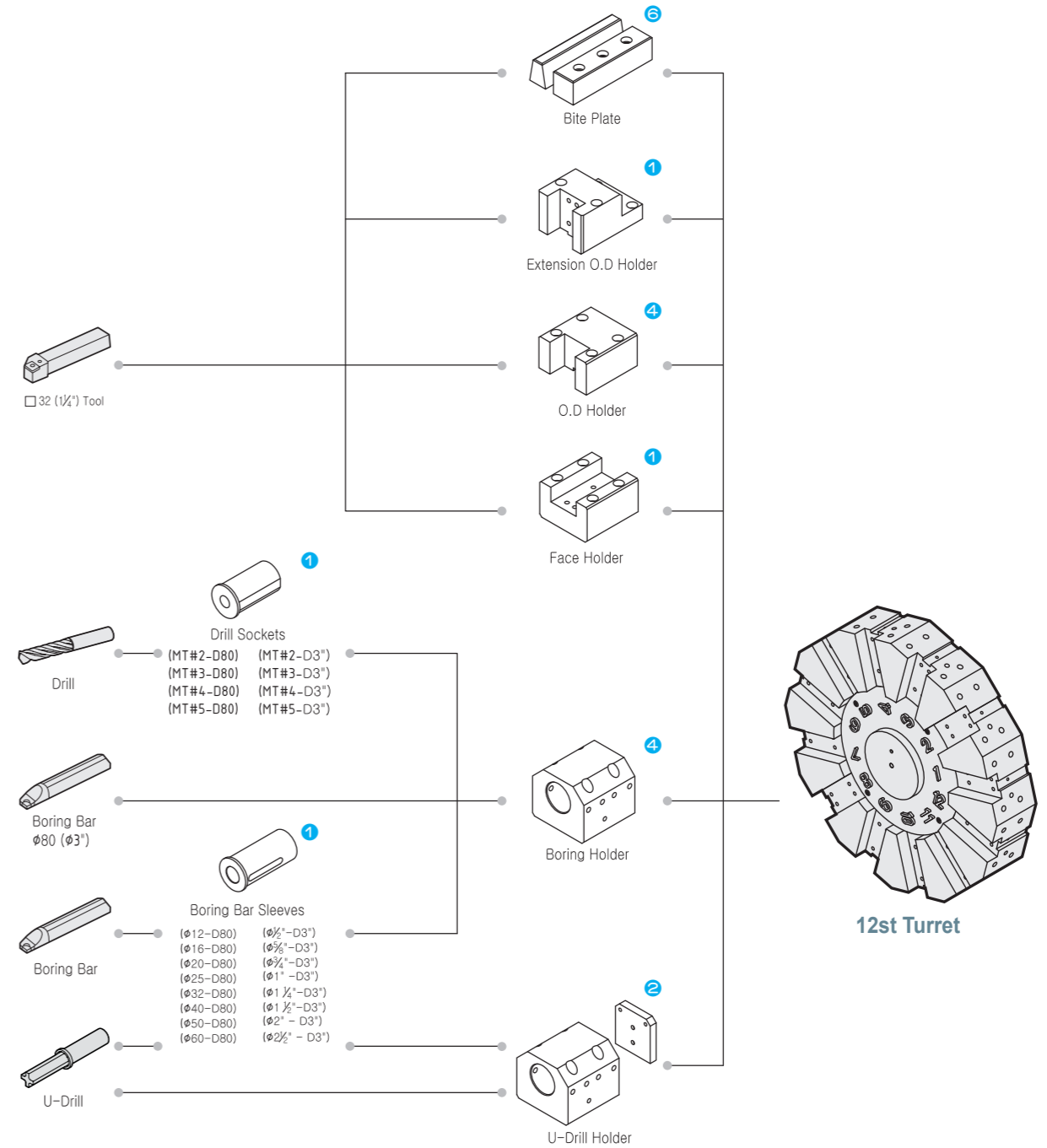

● : Standard Set Numbers

Tooling System

PL 60M / 60XM / 60LM / 60XLM

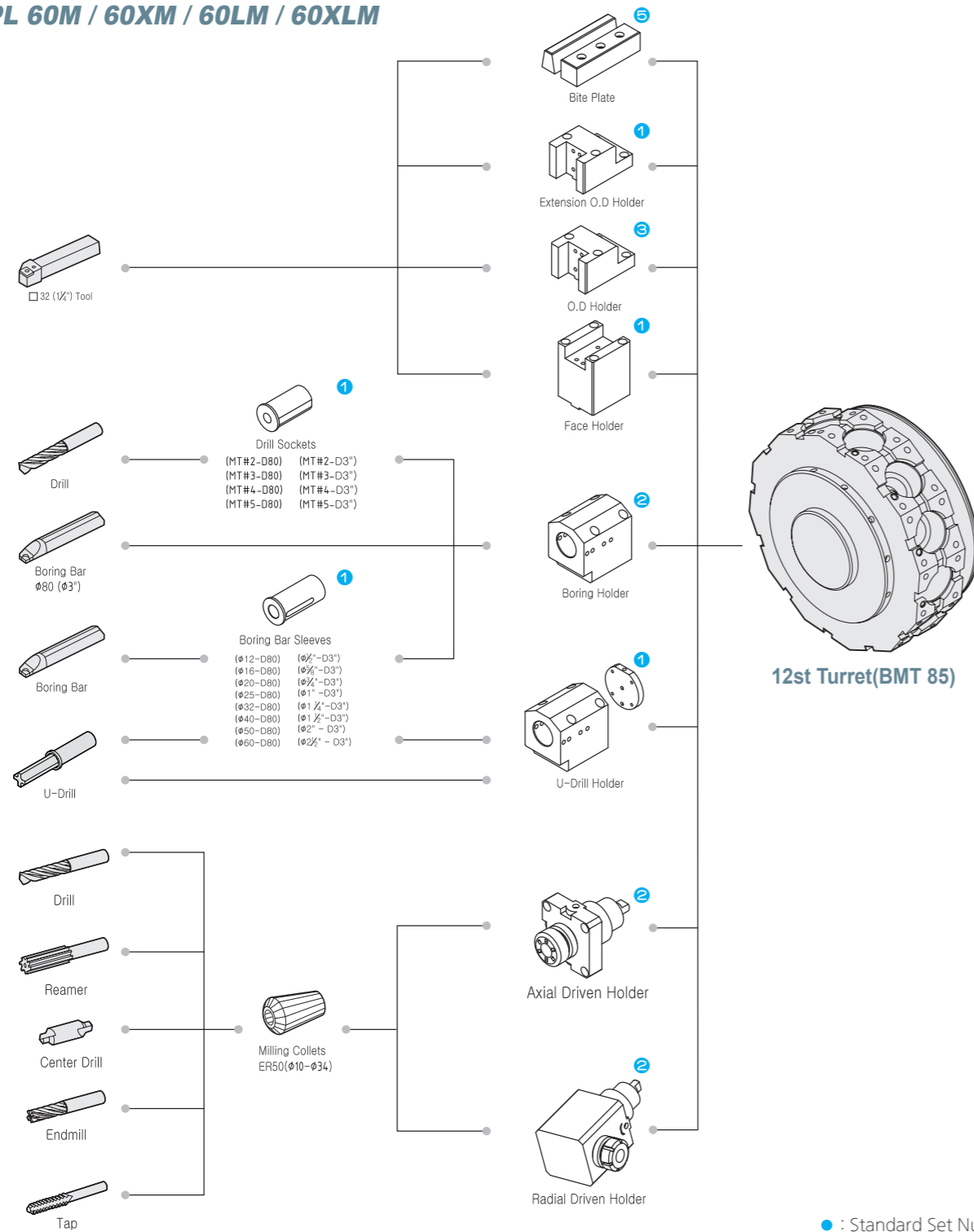

Machine Dimensions

Unit : mm

PL 60/60M

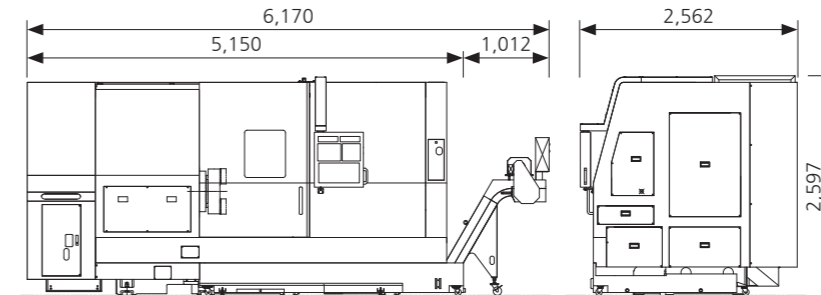

PL 60L/60LM

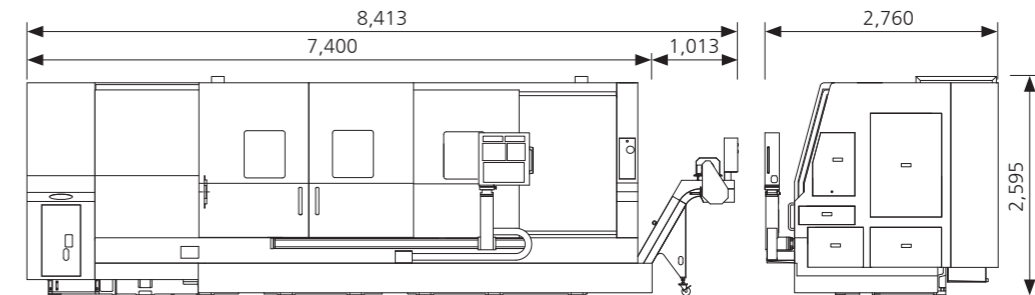

PL 60X/60XM

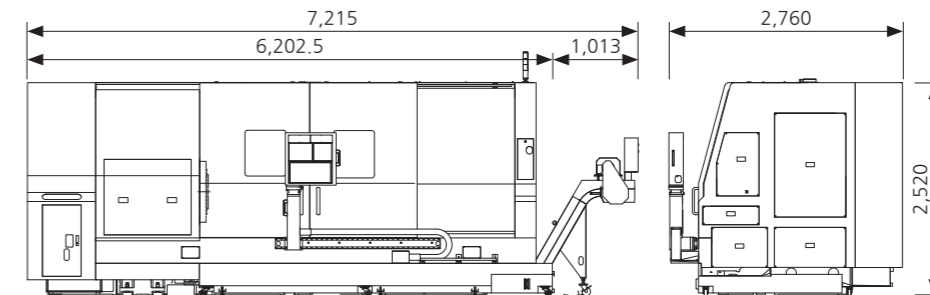

PL 60XL/60XLM

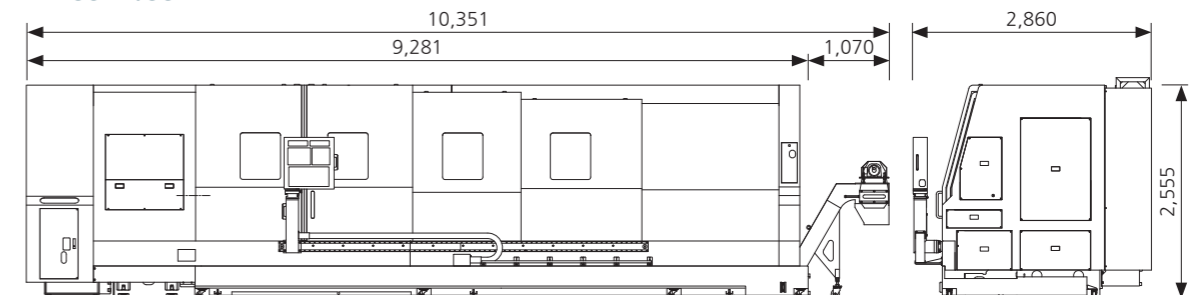

Work Range

Unit : mm

FACE CUT

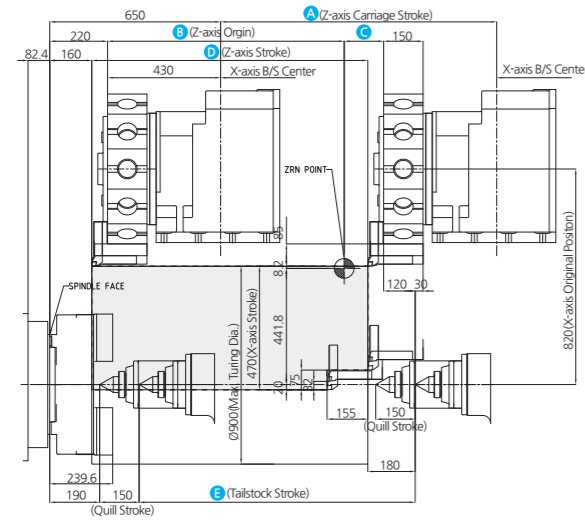

	PL 60	PL 60X	PL 60L	PL 60XL
A	1,050mm	2,050mm	3,270mm	5,100mm
B	900mm	1,900mm	3,070mm	4,900mm
C	150mm	150mm	200mm	200mm
D	1,050mm	2,050mm	3,270mm	5,100mm
E	1,050mm	2,050mm	3,270mm	5,100mm

BORING CUT

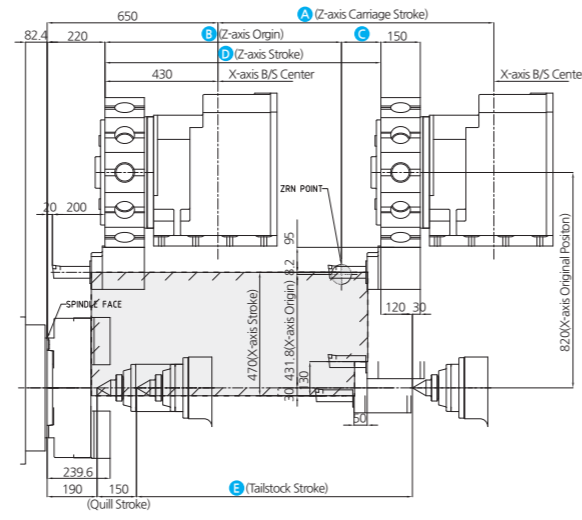

	PL 60	PL 60X	PL 60L	PL 60XL
A	1,050mm	2,050mm	3,270mm	5,100mm
B	900mm	1,900mm	3,070mm	4,900mm
C	150mm	150mm	200mm	200mm
D	1,050mm	2,050mm	3,270mm	5,100mm
E	1,050mm	2,050mm	3,270mm	5,100mm

BORING & RADIAL DRIVEN

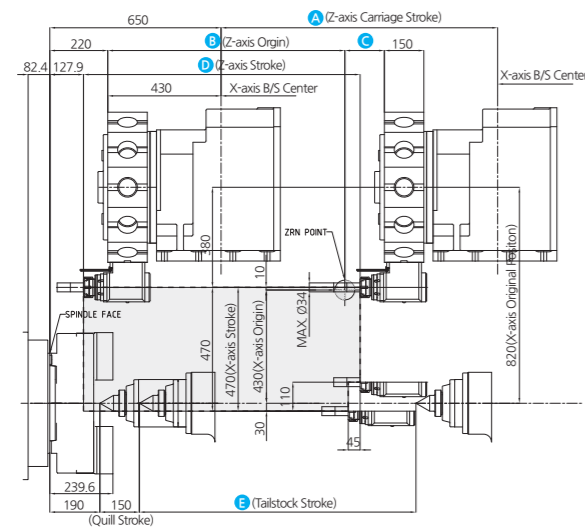

	PL 60M	PL 60XM	PL 60LM	PL 60XLM
A	1,050mm	2,050mm	3,270mm	5,100mm
B	900mm	1,900mm	3,070mm	4,900mm
C	150mm	150mm	200mm	200mm
D	1,050mm	2,050mm	3,270mm	5,100mm
E	1,050mm	2,050mm	3,270mm	5,100mm

FACE & AXIAL DRIVEN

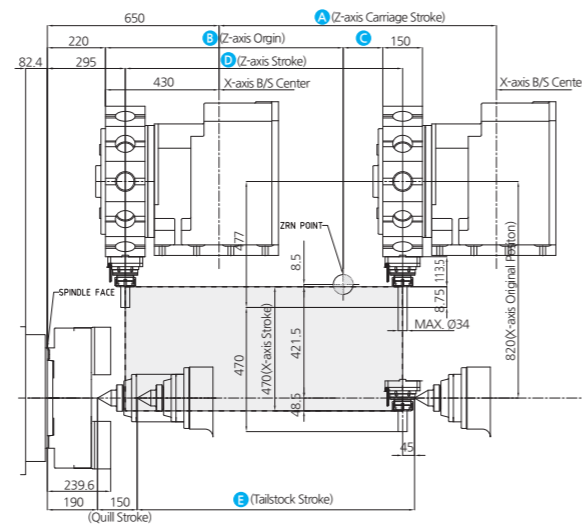

	PL 60M	PL 60XM	PL 60LM	PL 60XLM
A	1,050mm	2,050mm	3,270mm	5,100mm
B	900mm	1,900mm	3,070mm	4,900mm
C	150mm	150mm	200mm	200mm
D	1,050mm	2,050mm	3,270mm	5,100mm
E	1,050mm	2,050mm	3,270mm	5,100mm

Turret Head Interference

Unit : mm

PL 60/60X/60L/60XL (STD 12 station)

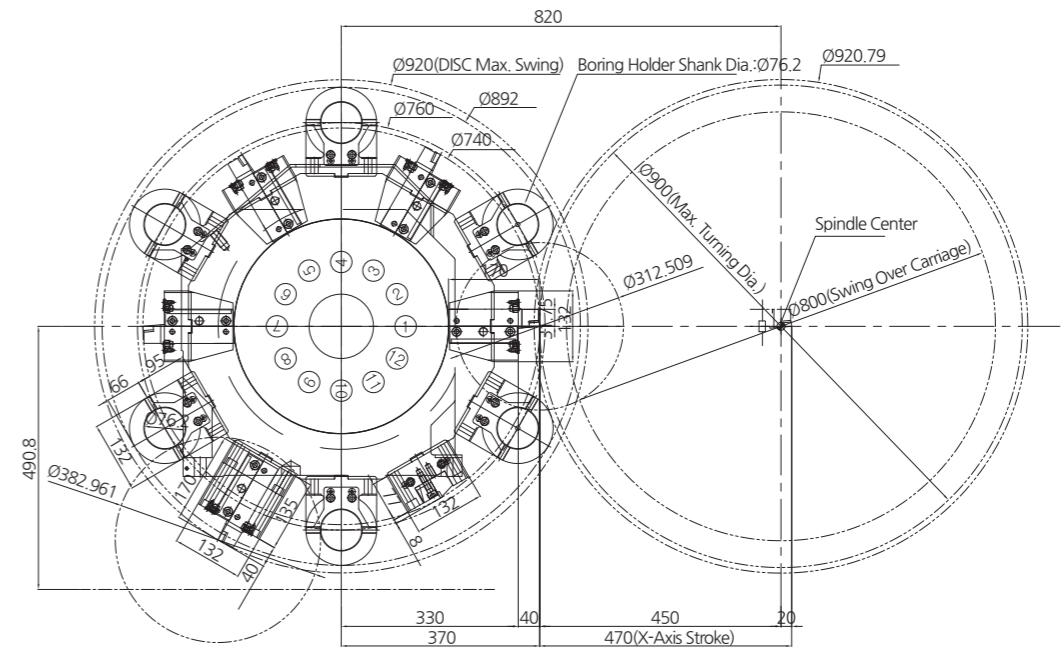

PL 60M/60XM/60LM/60XLM (BMT 75)

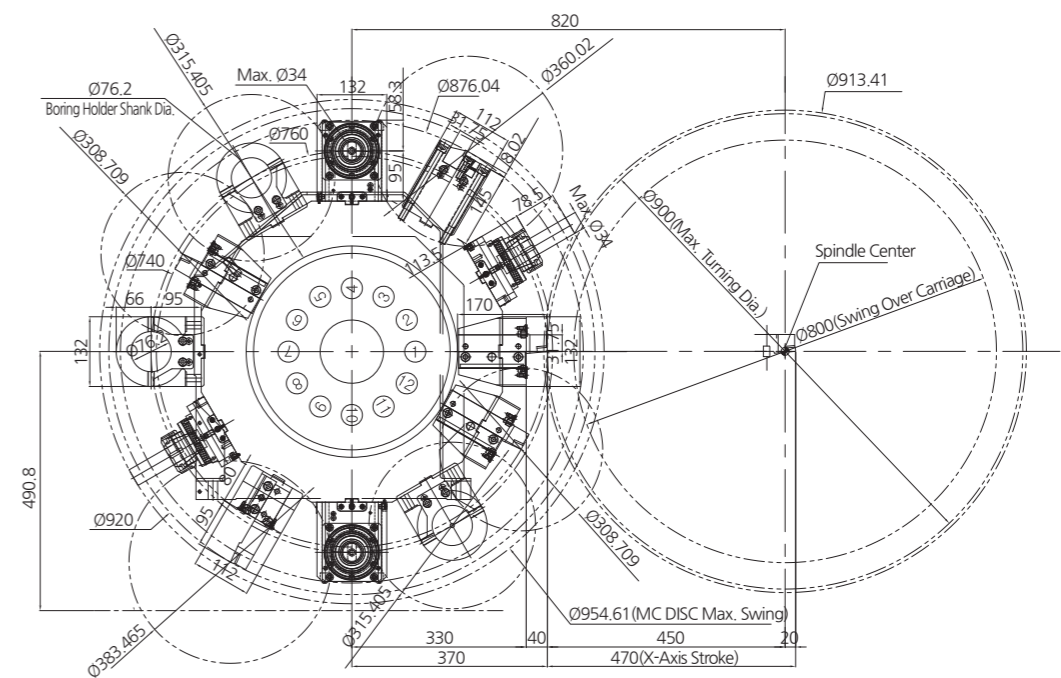

Major Specifications

DESCRIPTION		PL 60	PL 60M	PL 60X	PL 60XM
Capacity	Swing over the bed	mm	1,030	1,030	1,030
	Swing over the cross slide	mm	800	800	800
	Recom. turning diameter	mm	530	530	530
	Max. turning diameter	mm	900	900	900
	Max. turning length	mm	1,000	1,000	2,070
	Bar working diameter	mm	139.5	139.5	139.5
Travels	X axis travel	mm	470	470	470
	Y axis travel	mm	1,050	1,050	2,000
Main Spindle	Max. spindle speed	rpm	1,500	1,500	1,500
	Chuck size	inch	21"	21"	21"
	Spindle nose	ASA	A2-15	A2-15	A2-15
	Spindle through hole diameter	mm	Ø152	Ø152	Ø152
	Min. spindle indexing angle(C-Axis)	deg	0.001	0.001	0.001
Turret (STD.)	Number of tool stations [option]	ea	12(STD)	12(STD)	12(STD)
	Shank size for square tool	mm	□ 32	□ 32	□ 32
	Shank diameter for boring bar	mm	Ø80	Ø80	Ø80
Turret (MC)	Number of tool stations [option]	ea	12(BMT85)	12(BMT85)	12(BMT85)
	Shank size for square tool	mm	□ 32	□ 32	□ 32
	Shank diameter for boring bar	mm	Ø80	Ø80	Ø80
	Indexing time	sec	0.25	0.25	0.25
	Rotary tool spindle speed	rpm	3,000	3,000	3,000
Feed Rate	Rapid traverse (X/Z)	m/min	12 / 18	12 / 18	12 / 18
	Feed per revolution	mm/rev	0.0016~500	0.0016~500	0.0016~500
Motor	X axis feed motor	kW	7	7	7
	Z axis feed motor	kW	6	6	6
	Spindle drive motor(cont./30min)	kW	37 / 45	37 / 45	37 / 45
	Rotary tool spindle motor(cont./30min)	kW	7.5 / 11	7.5 / 11	7.5 / 11
	Tailstock travel	mm	1,050	1,050	2,050
Tailstock	Quill diameter	mm	Ø180	Ø180	Ø180
	Quill bore taper	MT	MT-6 (BUILT-IN)	MT-6 (BUILT-IN)	MT-6 (BUILT-IN)
	Quill travel	mm	150	150	150
	ELECTRIC POWER SUPPLY	kVA/V	65(69)	65(69)	65(69)
REQUIRED FLOOR SPACE(L×W)	mm	5,158×2,564	5,158×2,564	6,203×2,760	
MACHINE WEIGHT	kg	16,500	16,500	19,000	
CONTROLLER					

※Figures in inches are converted from metric measurements.

Major Specifications

DESCRIPTION		PL 60L	PL 60LM	PL 60XL	PL 60XLM
Capacity	Swing over the bed	mm	1,030	1,030	1,030
	Swing over the cross slide	mm	800	800	800
	Recom. turning diameter	mm	530	530	530
	Max. turning diameter	mm	900	900	900
	Max. turning length	mm	3,200	3,200	5,050
	Bar working diameter	mm	139.5	139.5	139.5
Travels	X axis travel	mm	470	470	470
	Y axis travel	mm	3,270	3,270	5,100
Main Spindle	Max. spindle speed	rpm	1,500	1,500	1,500
	Chuck size	inch	21"	21"	21"
	Spindle nose	ASA	A2-15	A2-15	A2-15
	Spindle through hole diameter	mm	Ø152	Ø152	Ø152
	Min. spindle indexing angle(C-Axis)	deg	0.001	0.001	0.001
Turret (STD.)	Number of tool stations [option]	ea	12(STD)	12(STD)	12(STD)
	Shank size for square tool	mm	□ 32	□ 32	□ 32
	Shank diameter for boring bar	mm	Ø80	Ø80	Ø80
Turret (MC)	Number of tool stations [option]	ea	12(BMT85)	12(BMT85)	12(BMT85)
	Shank size for square tool	mm	□ 32	□ 32	□ 32
	Shank diameter for boring bar	mm	Ø80	Ø80	Ø80
	Indexing time	sec	0.25	0.25	0.25
	Rotary tool spindle speed	rpm	3,000	3,000	3,000
Feed Rate	Rapid traverse (X/Z)	m/min	12 / 18	12 / 18	12 / 18
	Feed per revolution	mm/rev	0.0016~500	0.0016~500	0.0016~500
Motor	X axis feed motor	kW	7	7	7
	Z axis feed motor	kW	6	6	6
	Spindle drive motor(cont./30min)	kW	37 / 45	37 / 45	37 / 45
	Rotary tool spindle motor(cont./30min)	kW	7.5 / 11	7.5 / 11	7.5 / 11
	Quill diameter	mm	Ø180	Ø180	Ø180
Tailstock	Quill bore taper	MT	MT-6 (BUILT-IN)	MT-6 (BUILT-IN)	MT-6 (BUILT-IN)
	Quill travel	mm	150	150	150
	ELECTRIC POWER SUPPLY	kVA/V	65(69)	65(69)	65(69)
	REQUIRED FLOOR SPACE(L×W)	mm	7,400×2,760	7,400×2,760	9,400×2,860
MACHINE WEIGHT	kg	22,000	22,000	26,000	
CONTROLLER		Fanuc Oi-TD (21i-TB)			

※Figures in inches are converted from metric measurements.

Standard Accessories

- COOLANT SYSTEM
- Built-in Work Light
- SPLASH GUARD
- Hand Tools
- 21" Hydraulic Chuck
- Soft Jaw 3 sets
- Hard Jaw 1 set
- TURRET HOLDER
- LEVELLING BLOCK
- PROGRAMMABLE TAILSTOCK
- Spindle ORIENTATION
- DOOR INTERLOCK

Optional Accessories

- CHIP CONVEYOR WITH BUCKET
- Steadyrest : SLU-5 ZS, SLU-5.1
- Dual Steadyrest : SLU-5 ZS, SLU-5.1
- Auto Door(L type, L/R type)
- High pressure Coolant (6,10,15 bar-60Hz)
- OIL SKIMMER
- COOLANT GUN
- AIR BLOWER
- TRANSFORMER
- Patrol Lamp